

# Item #: ISLB5C

## Assembly Instructions

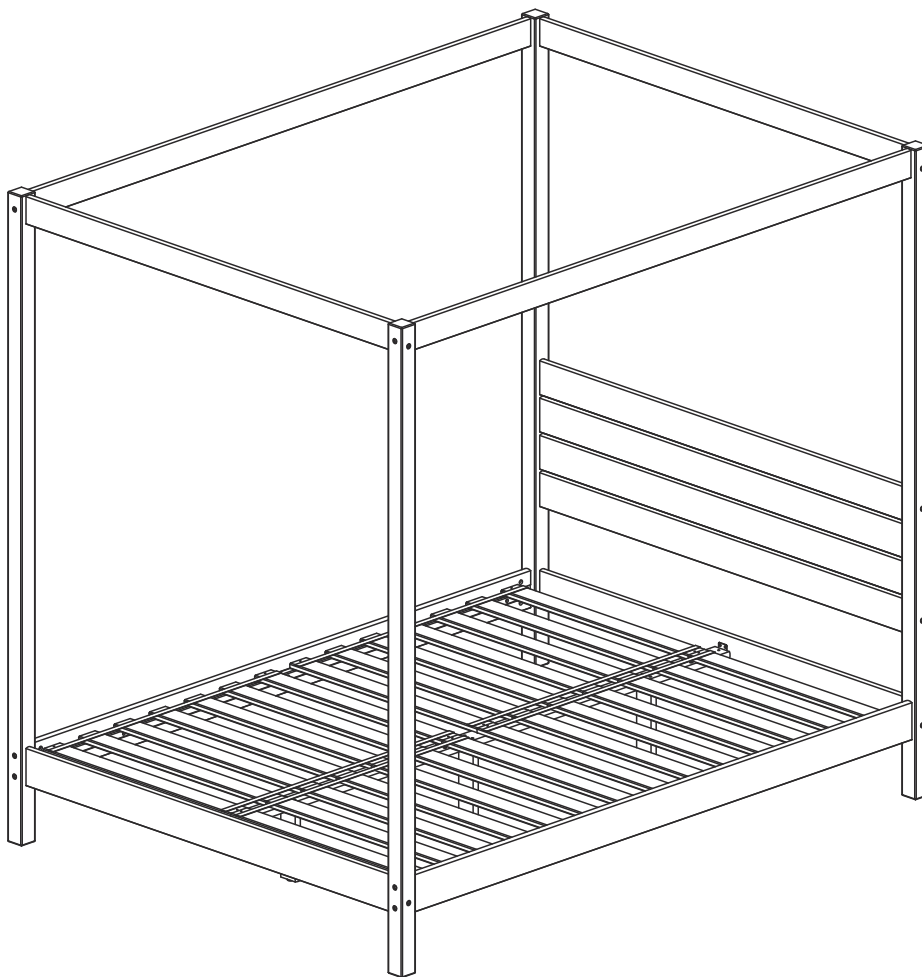

Please visit our website for the most current instructions, assembly tips, to report damage or request parts. [www.walkeredison.com](http://www.walkeredison.com)

Revised 06/2023 - V1

# General assembly guidelines

- I. Ensure that all parts and hardware are available before beginning assembly.
- II. Follow each step carefully to ensure the proper assembly of this product.
- III. Two people are recommended for ease in the assembly of this product.
- IV. The three main types of hardware used to assemble this product are wood dowels, screws and bolts.
- V. A hammer, Phillips head and Slotted head screwdrivers are required for the assembly of this product.

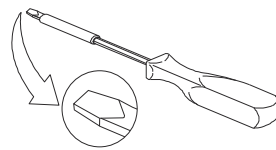
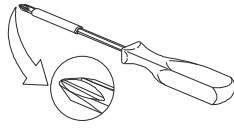
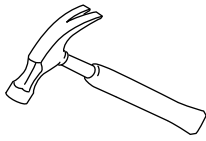

- VI. Power tools should not be used to assemble this product.

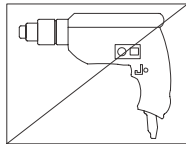



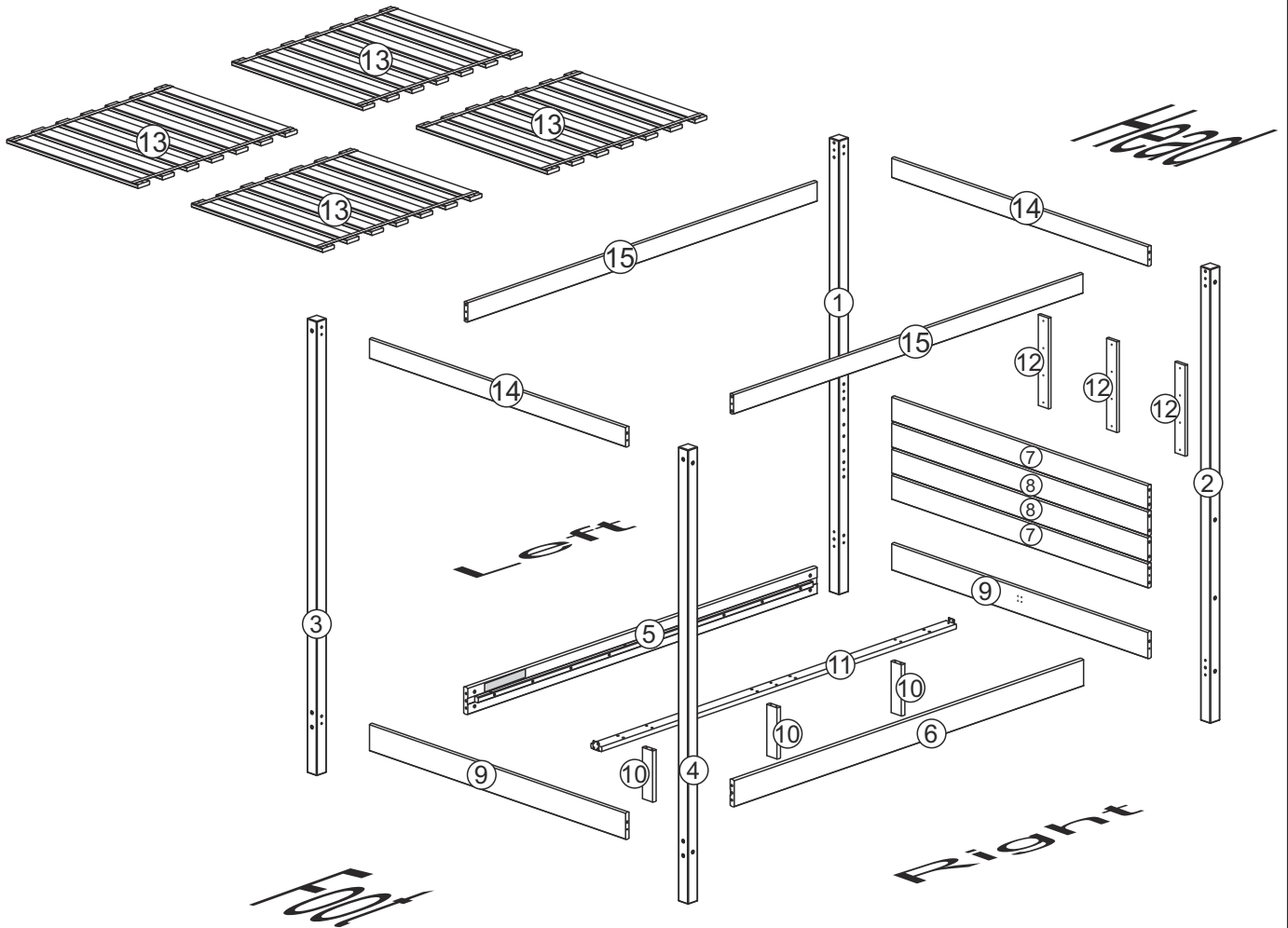





# Parts List

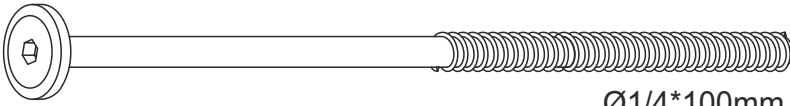

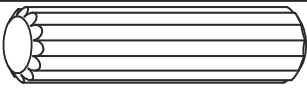
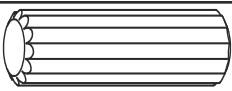
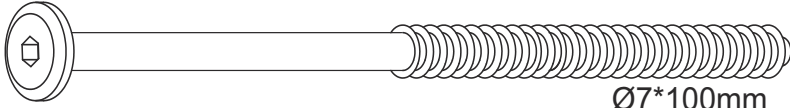
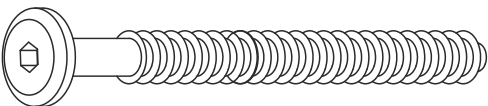
Part#	Description	Qty
1	Headboard Left Foot	1
2	Headboard Right foot	1
3	Footboard Left Foot	1
4	Footboard Right foot	1
5	Left side rail	1
6	Right Side Rail	1
7	Upper Rail / Lower Slat(HEADBOARD)	2
8	Middle Slat (HEADBOARD)	2
9	Head/Foot Rail	2

Part#	Description	Qty
10	Central Foot	3
11	Central Support	1
12	Union Support	3
13	Set Slat	4
14	Upper Short Slat	2
15	Upper Long Slat	2

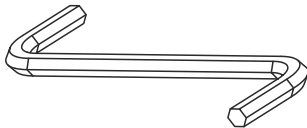
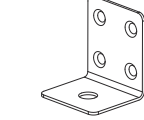
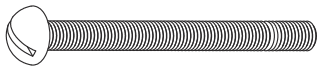
# Hardware List

<b>A</b>	 Ø1/4*100mm	Bolt (Head 13)	08 pcs	
<b>B</b>		1/4mm	Barrel nut	08 pcs
<b>C</b>		Ø10*40mm	Wooden dowel	36 pcs
<b>D</b>		Ø10*30mm	Wooden dowel	16 pcs
<b>E</b>	 Ø7*100mm	Bolt (Head 13)	16 pcs	
<b>F</b>	 Ø7*60mm	Bolt (Head 13)	06 pcs	
<b>G</b>	 Ø4*35mm	Screw	16 pcs	
<b>H</b>	 Ø4*25mm	Screw	12 pcs	
<b>I</b>	 Ø3,5*16mm	Screw	08 pcs	
<b>J</b>			Hex Key	01 pcs
<b>K</b>			Corner Brace	02 pcs
<b>L</b>	 Ø3/16*1 1/2	Screw	02 pcs	
<b>M</b>	 Ø3/16	Nut	02 pcs	
<b>N</b>	 Ø3/16	Washer	02 pcs	

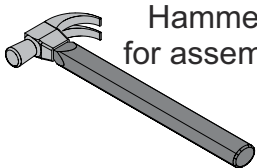

Hammer recommended for assembly (not included)

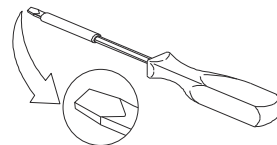
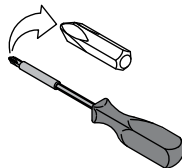

Phillips head and slotted head screwdrivers are required for assembly (not included)

The hardware quantities listed above are required for proper assembly. Some extra hardware may also have been included.

# Step 1

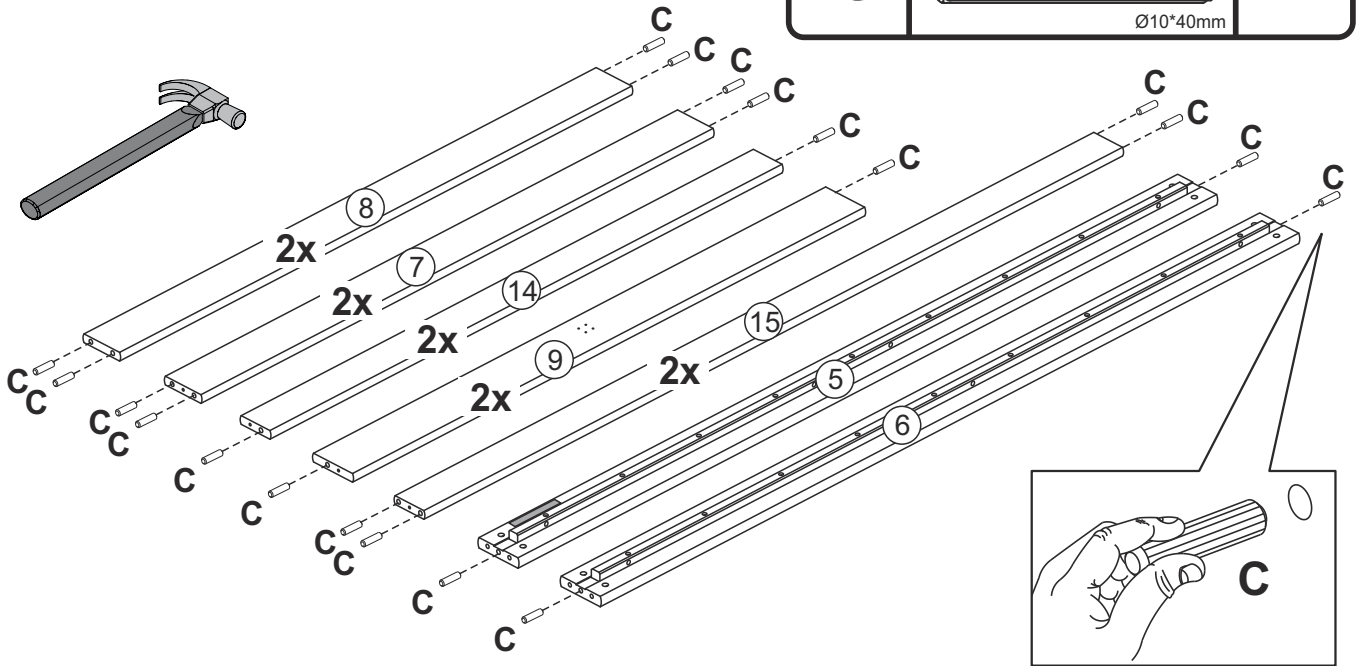
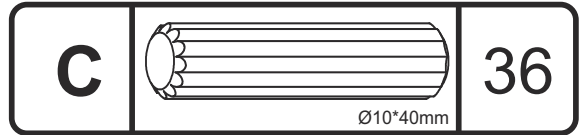

Insert wood dowel (C) into parts (5,6,7,8,9,14 and (15).

# Step 2

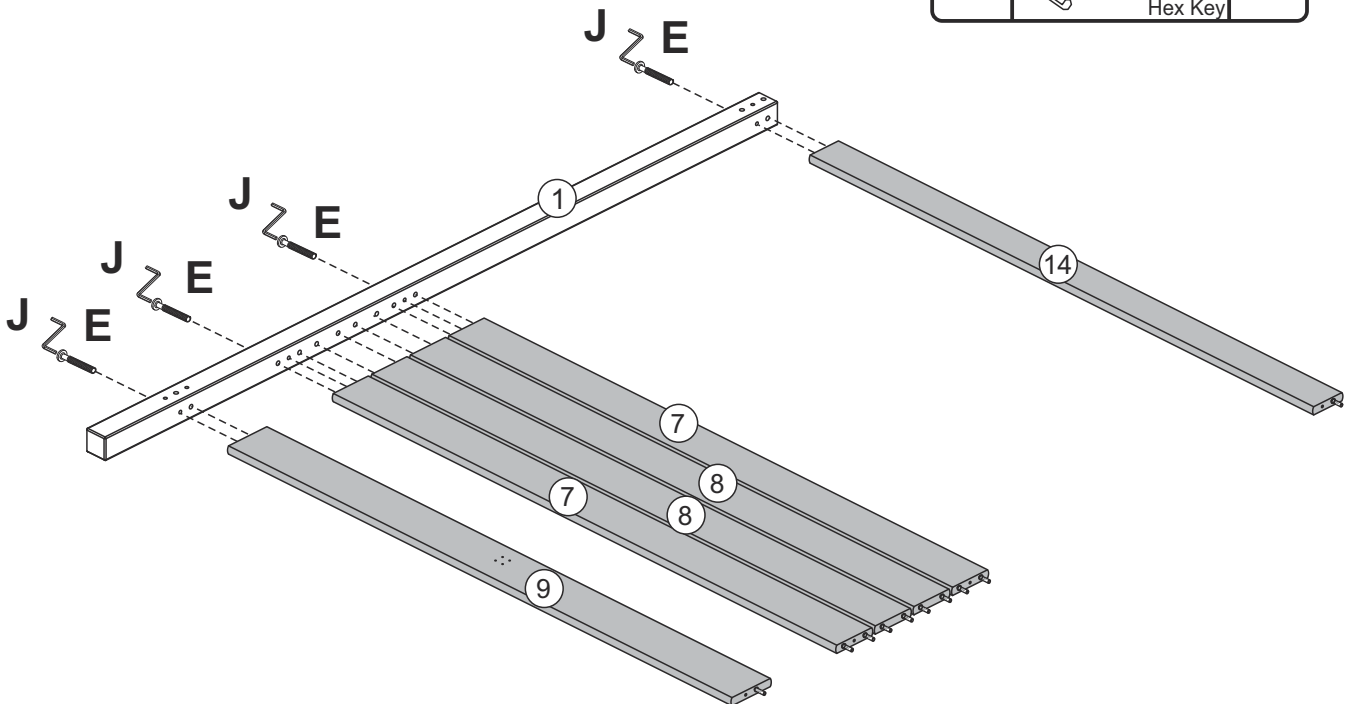
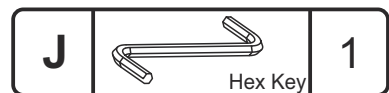
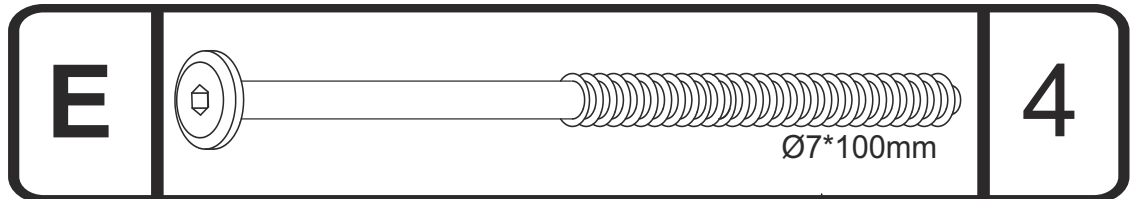

## HEADBOARD

Secure part 1 to parts 7, 8, 9 and 14 with screw (E) using Hex Key (J).

### Step 3

E

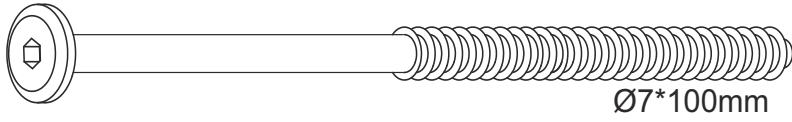

4

J

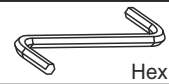

1

Hex Key

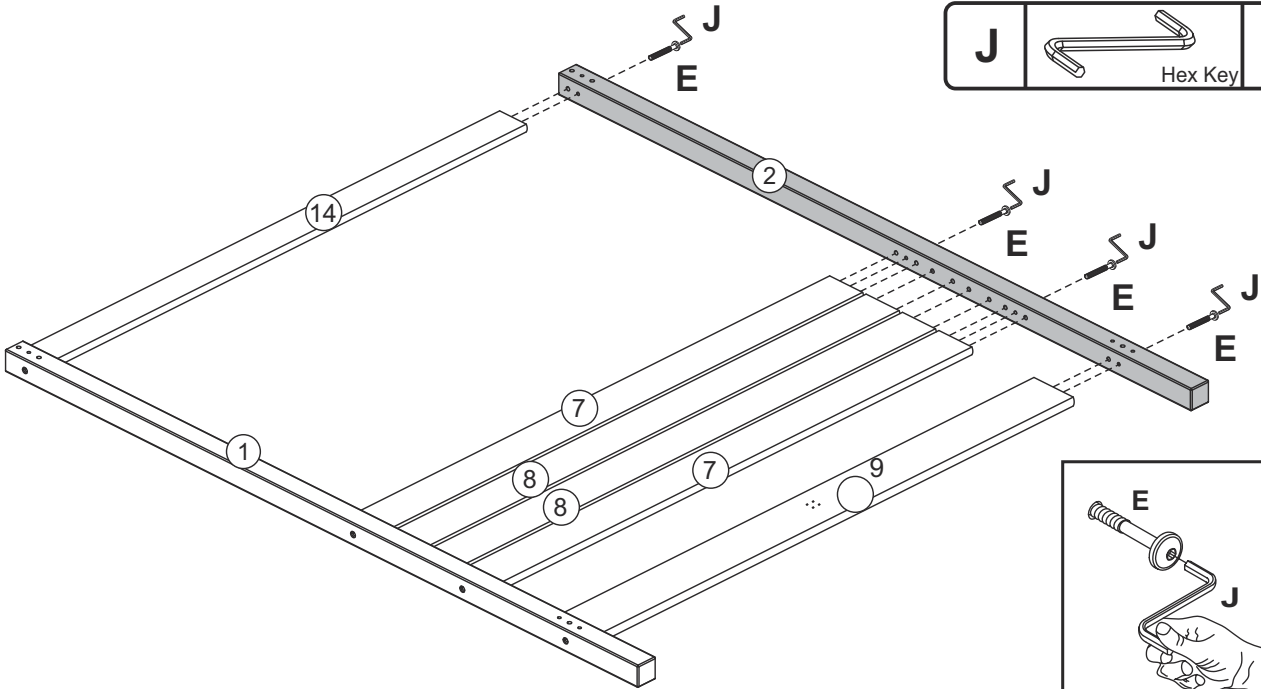

Secure part 2 to parts 7, 8, 9 and 14 with screw (E) using Hex Key (J).

### Step 4

H

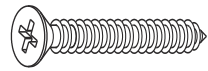

12

Pre Drilled Holes

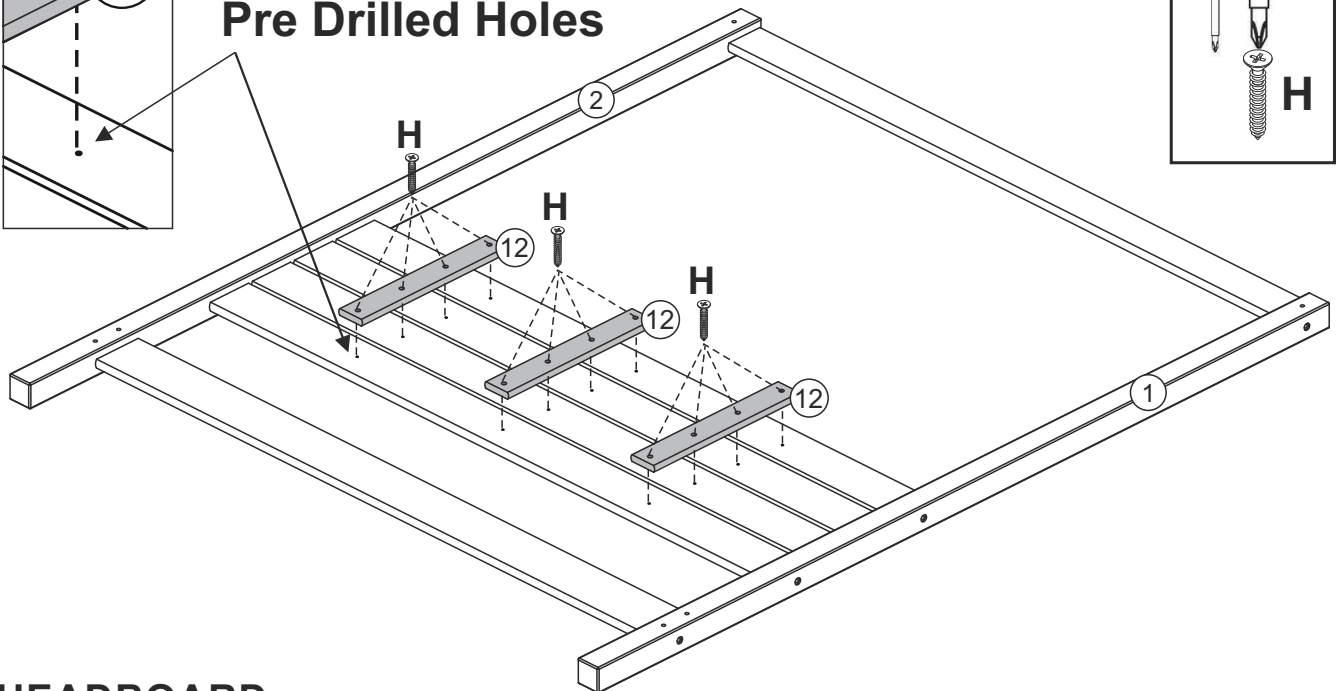
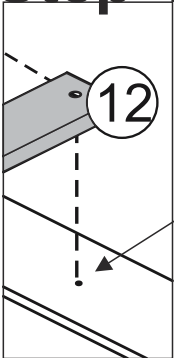

### HEADBOARD

Secure part 12 to headboard with screw (H) using phillips head screwdriver.

## Step 5

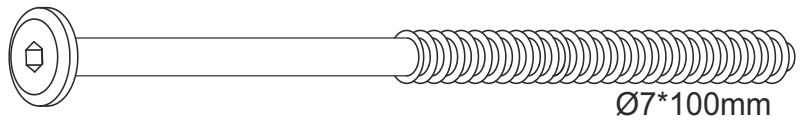
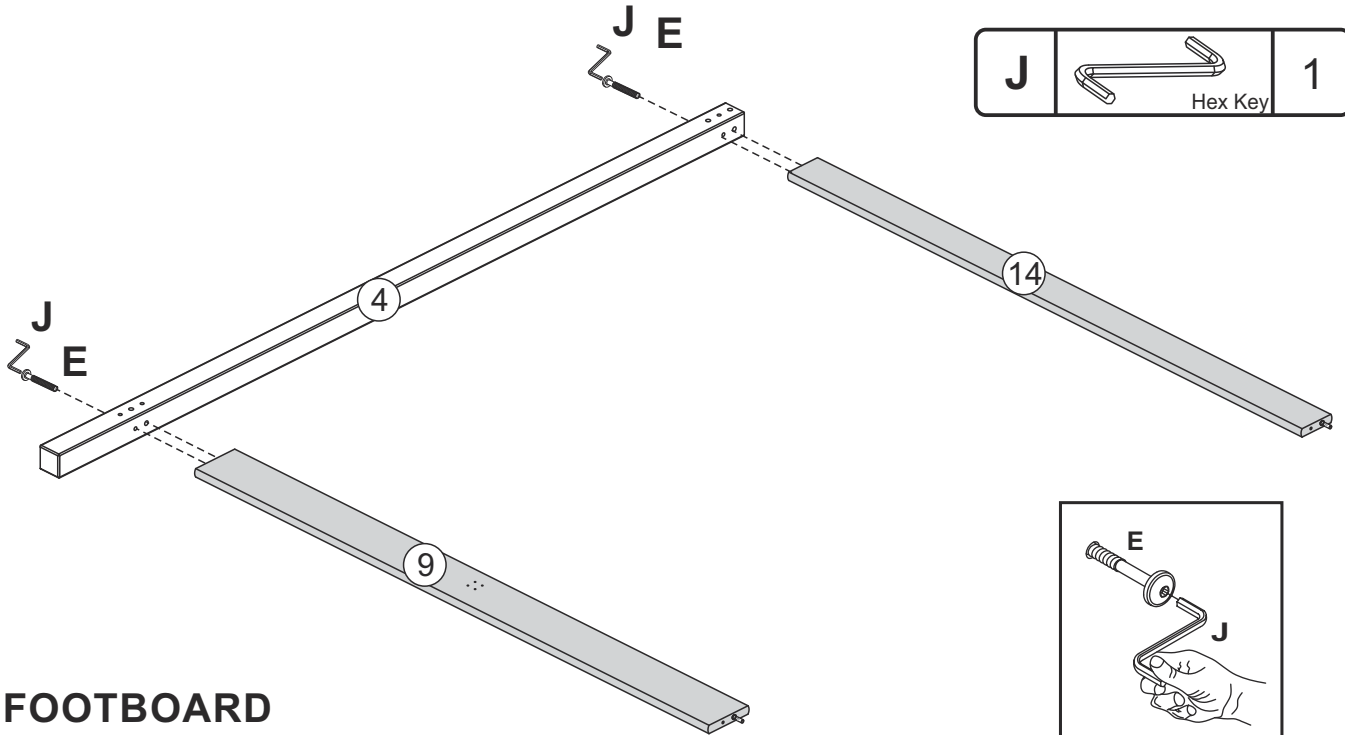
**E****2****J**

Hex Key

**1**

### FOOTBOARD

Secure part 4 to parts 9 and 14 with screw (E) using Hex Key (J).

## Step 6

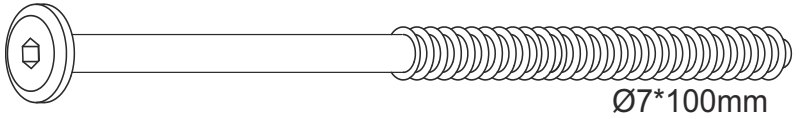
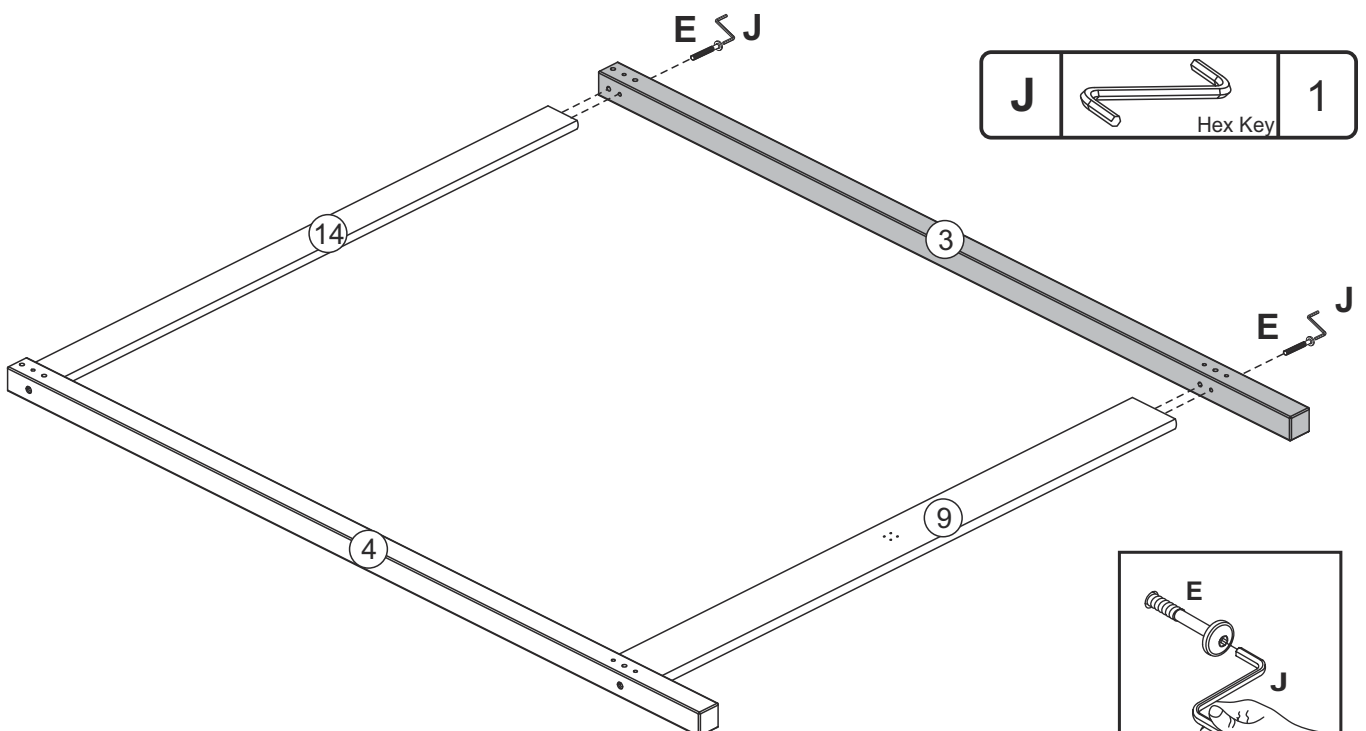
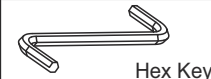
**E****2****J**

Hex Key

**1**

### FOOTBOARD

Secure part 3 to parts 9 and 14 with screw (E) using Hex Key (J).

## Step 7

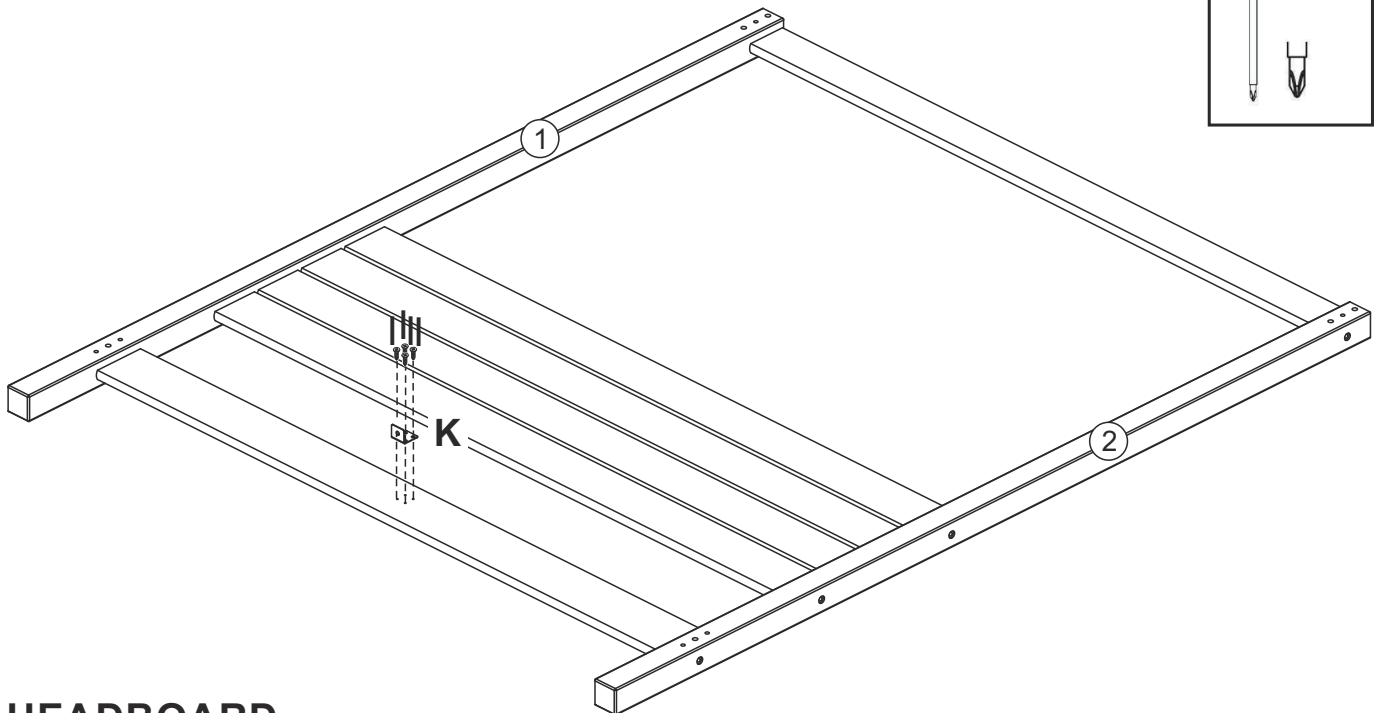
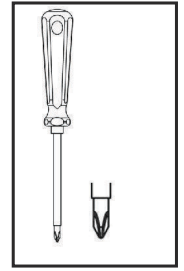

### HEADBOARD

Secure hardware (K) to headboard with screw (I) using phillips head screwdriver.

## Step 8

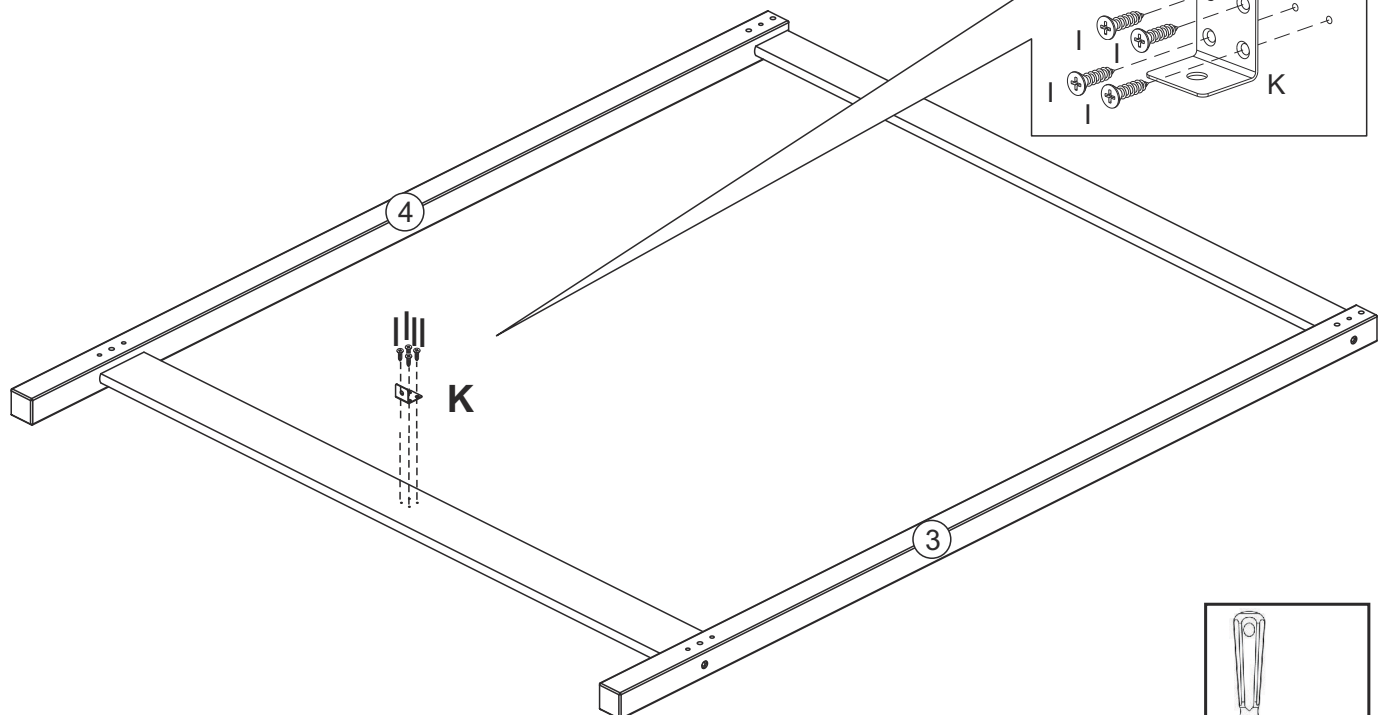
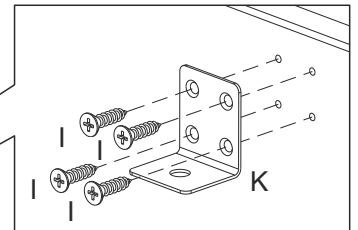

### FOOTBOARD

Secure hardware (K) to footboard with screw (I) using phillips head screwdriver.

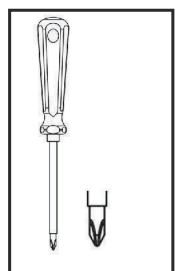



# Step 9

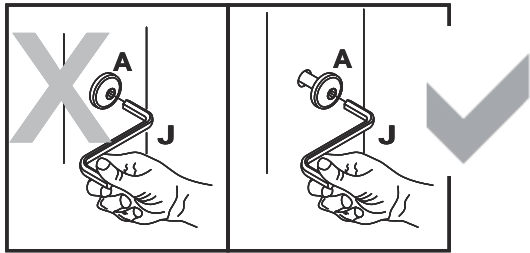

In this step, please do not tighten the screw all the way.

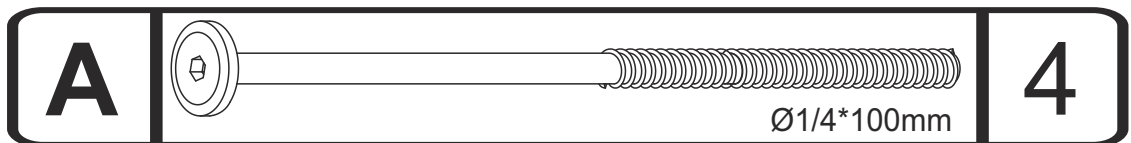
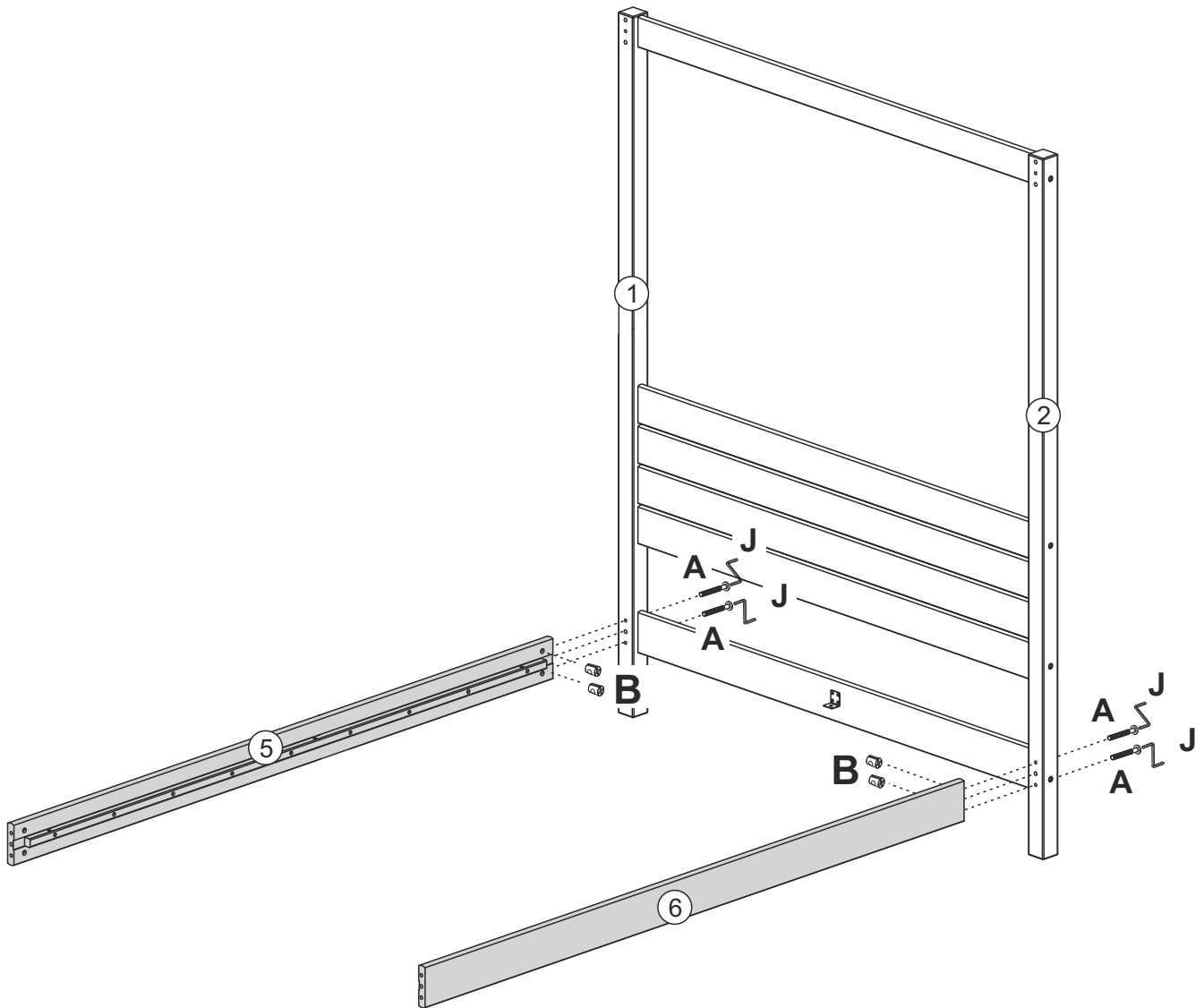

## HEADBOARD



Secure parts 5 and 6 to headboard with screw (A) and barrel nut (B) using Hex Key (J).

# Step 10

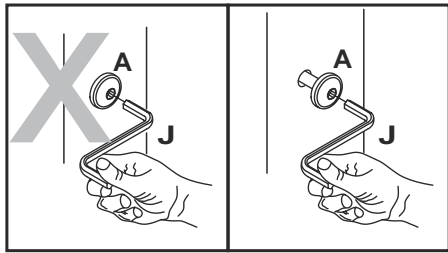

In this step, please do not tighten the screw all the way.

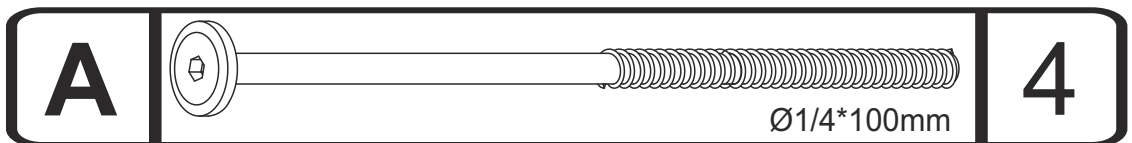
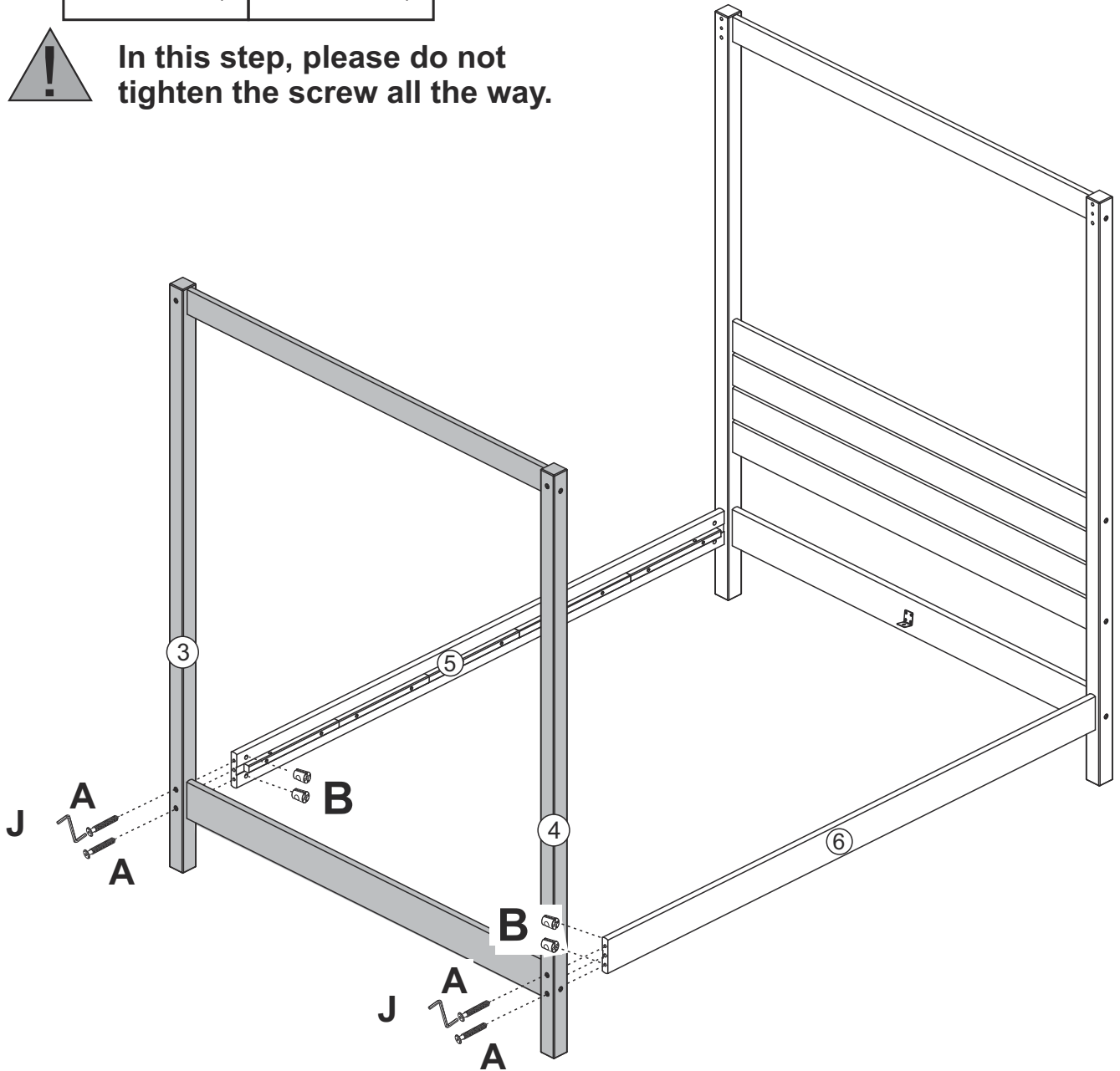

## FOOTBOARD



Secure part 5 and 6 to legs 3 and 4 with screw (A) and Barrow nut (B) using hex key (J).

# Step 11

# E

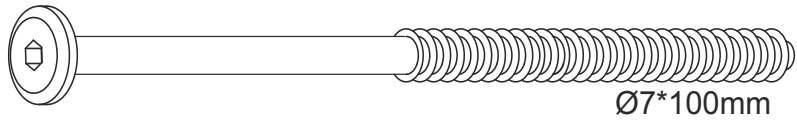

# 4

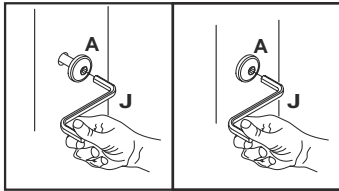
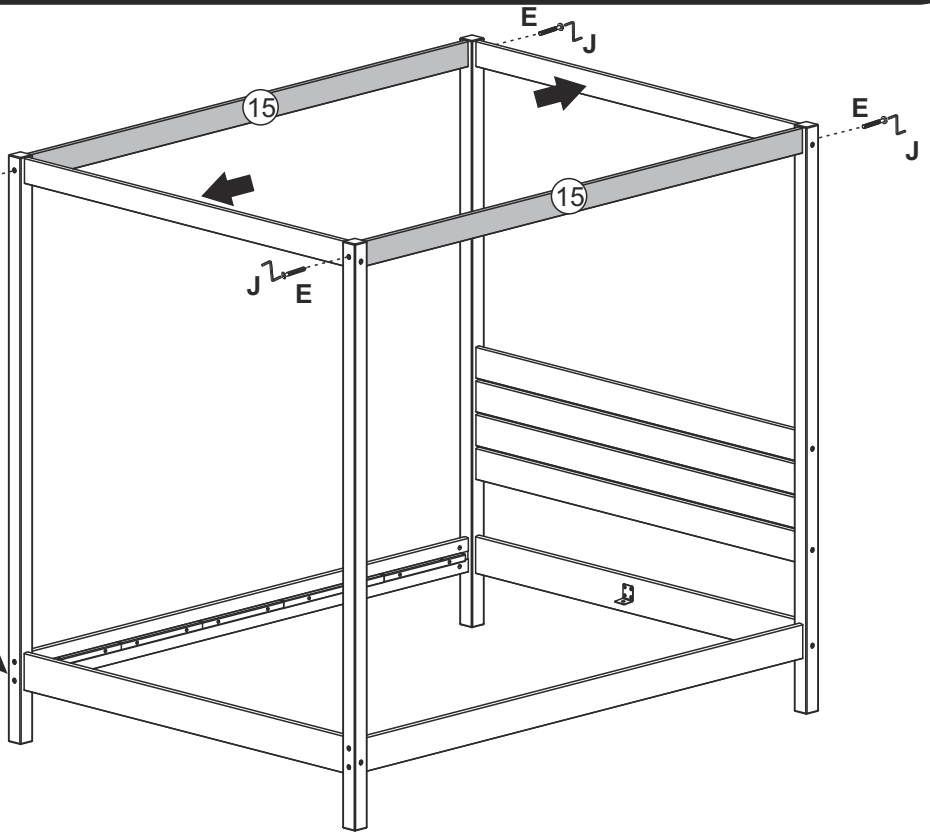
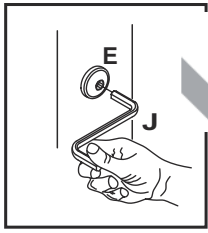

**!** Finish tightening the screws from steps 9 and 10.

Secure part 15 with screw (E) using Hex Key (J).



# Step 12

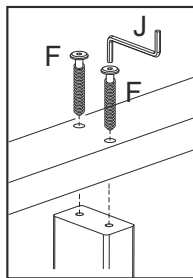
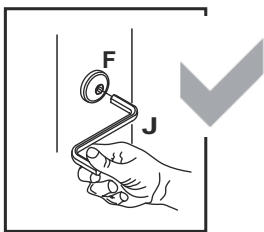

**!** In this step please tighten all screws to the end.

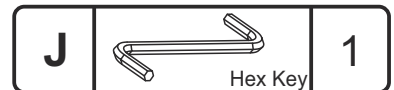
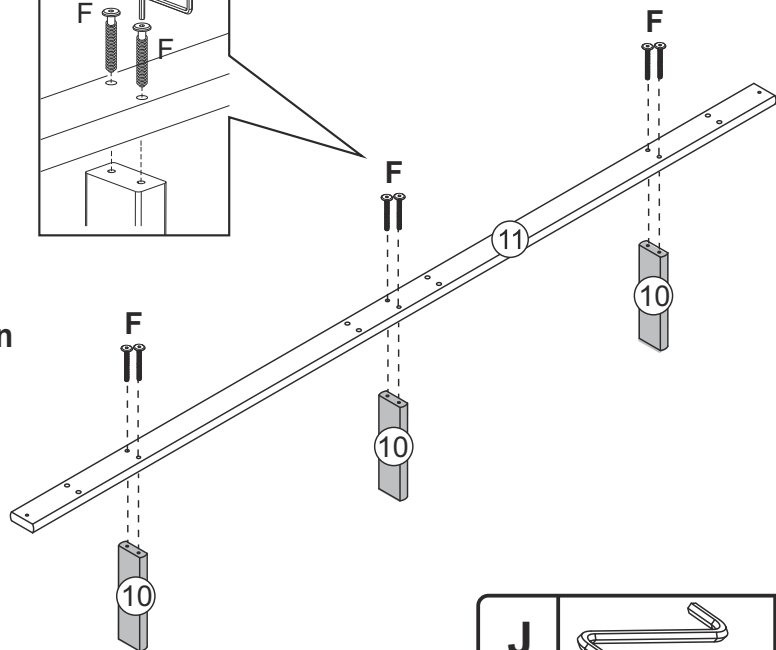

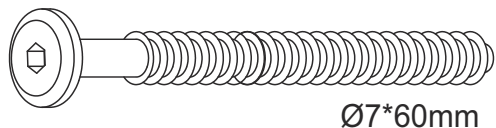

Secure part 11 to parts 10 with screw (F) using Hex Key (J).

# F



# 6

# Step 13

L		2	M		2	N		2
	Ø3/16*1 1/2			3/16			3/16	

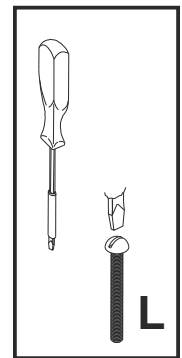
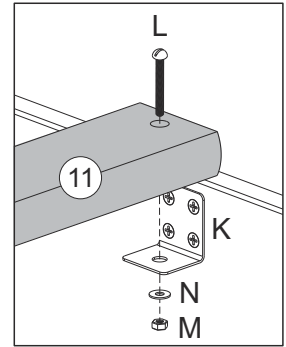
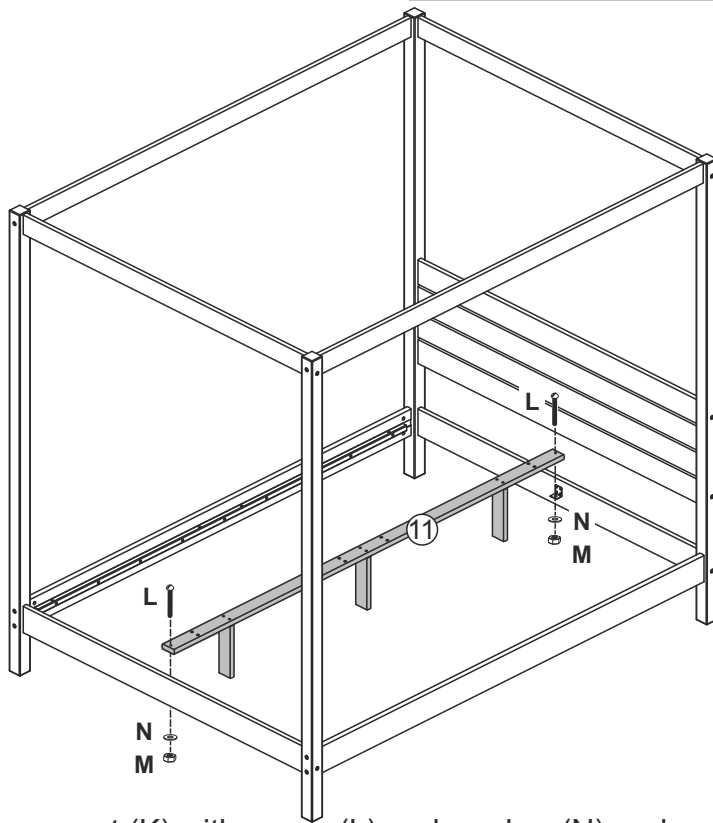

Secure part 11 to support (K) with screw (L) and washer (N) and nut (M) using slotted head screwdriver.

# Step 14

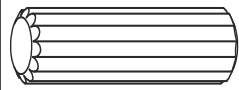
D		16
	Ø10*30mm	

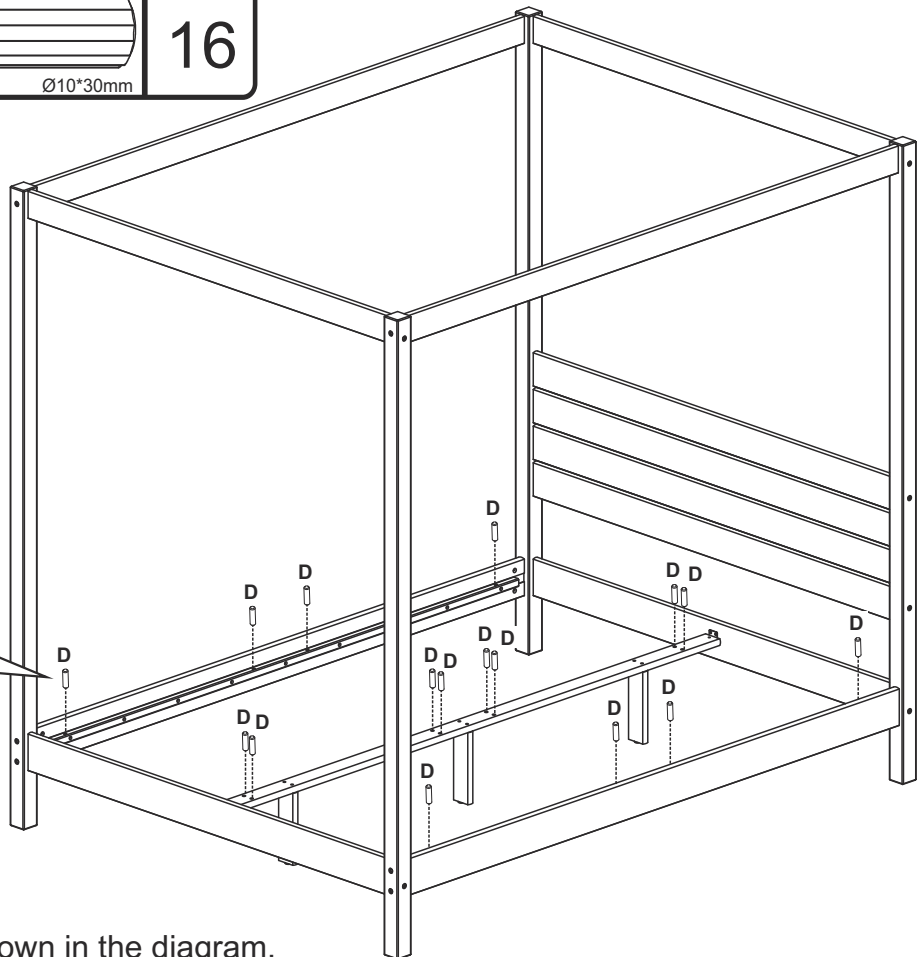
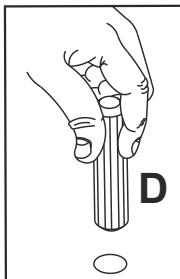
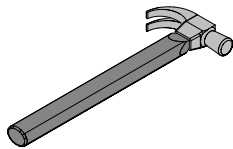

Insert wooden dowel (D) as shown in the diagram.

## Step 15

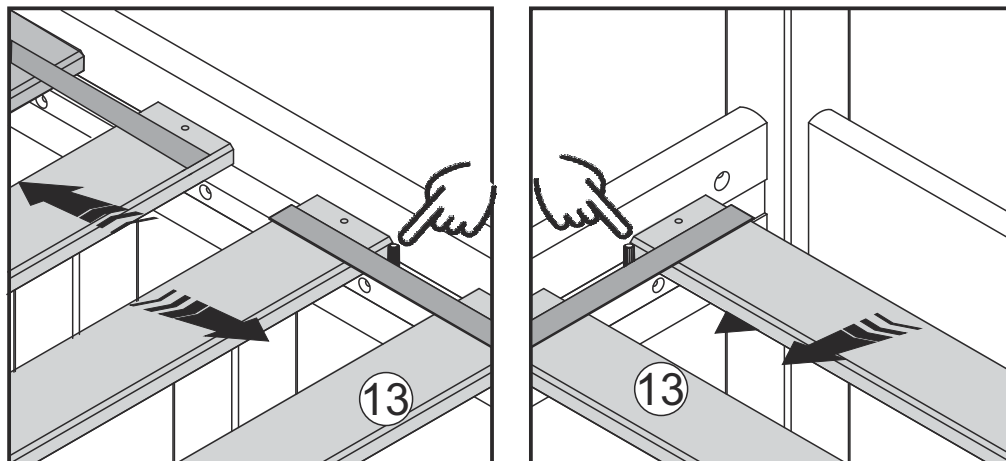

In this step, distribute sets of slats 13 using the applied dowels as guides.

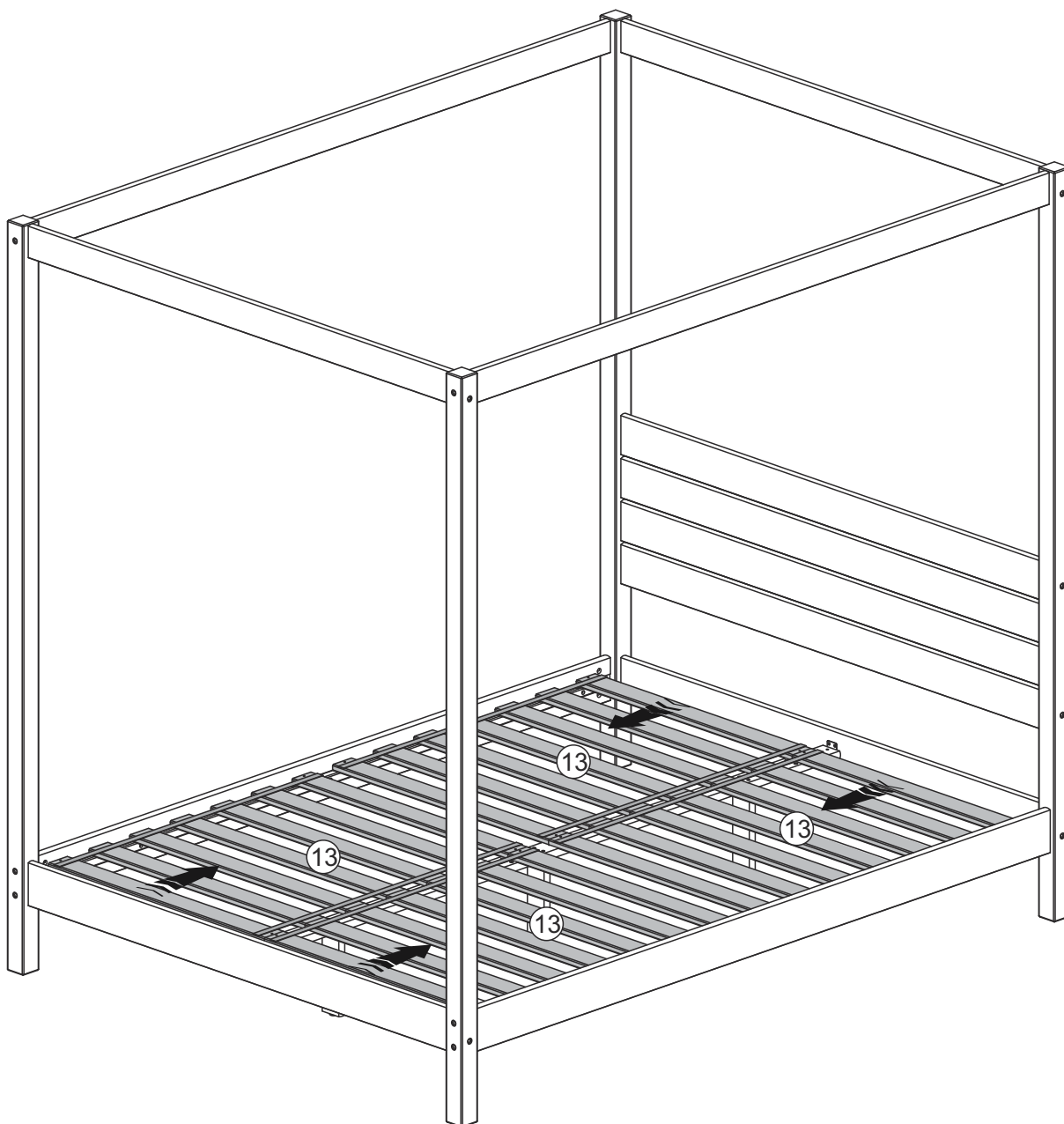

Insert the set of slats 13 as shown in the diagram.

# Step 16

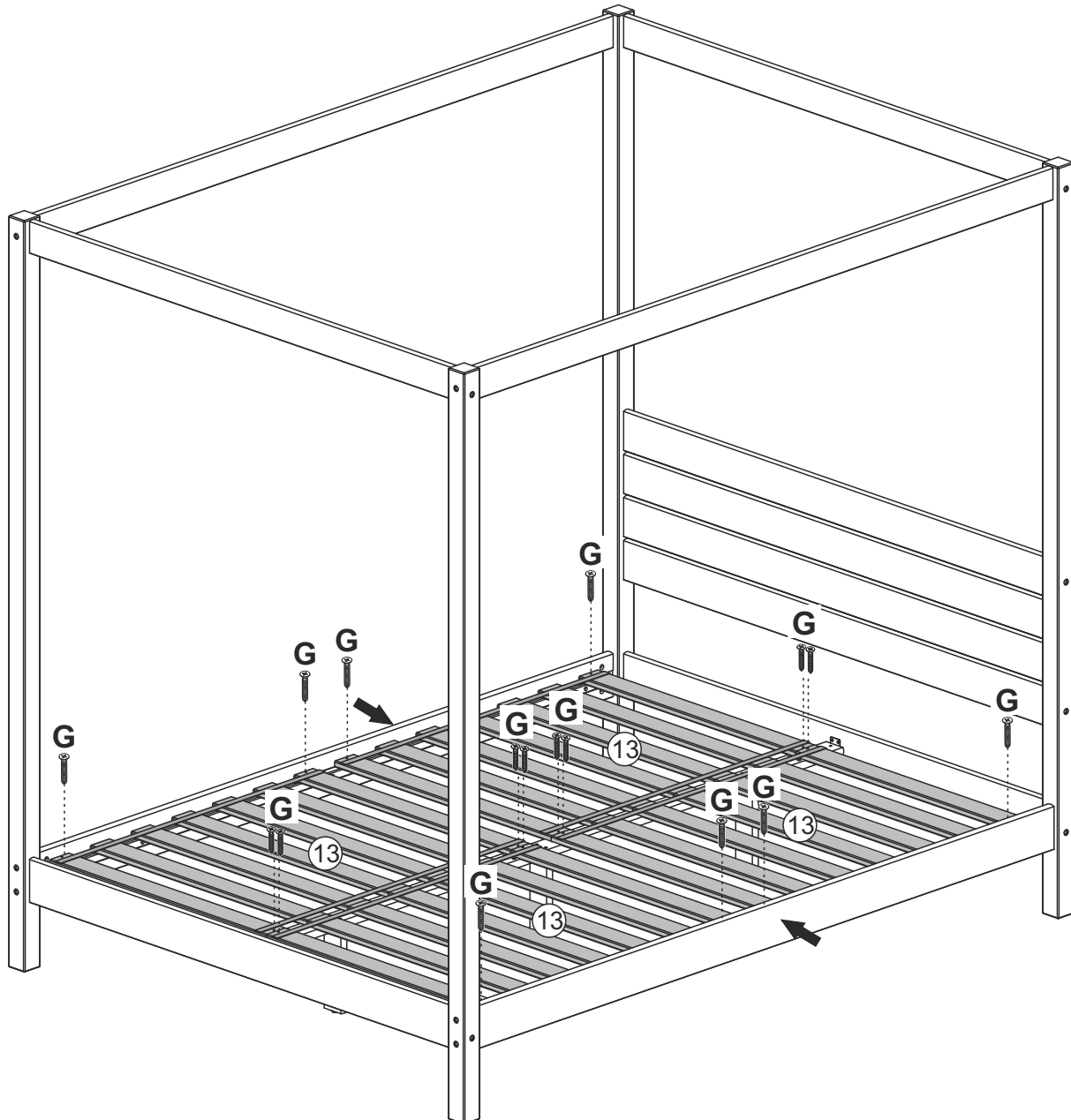
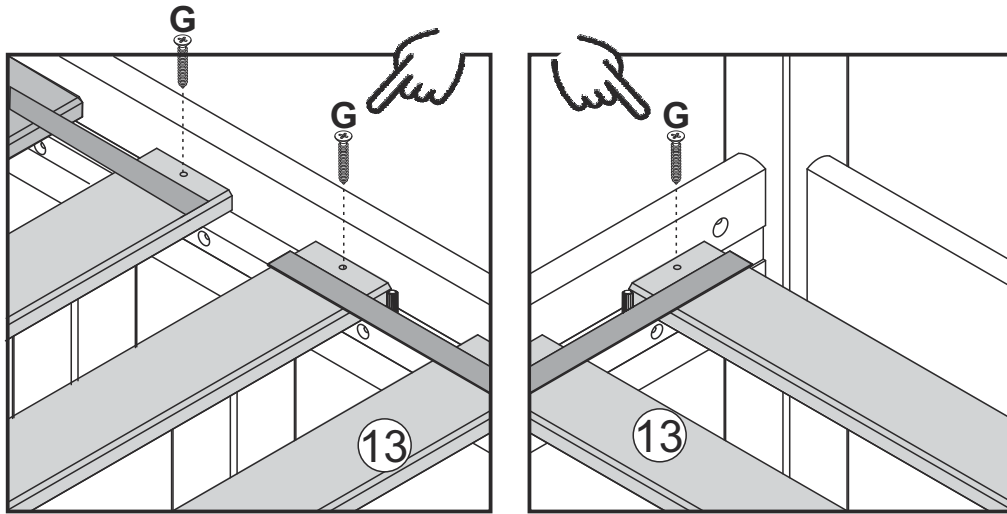
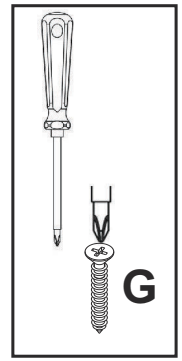
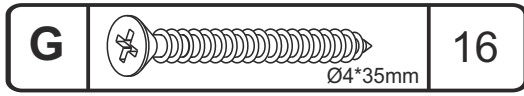

Secure the set of slats 18 with screw (G) using phillips head screwdriver.

# Step 17

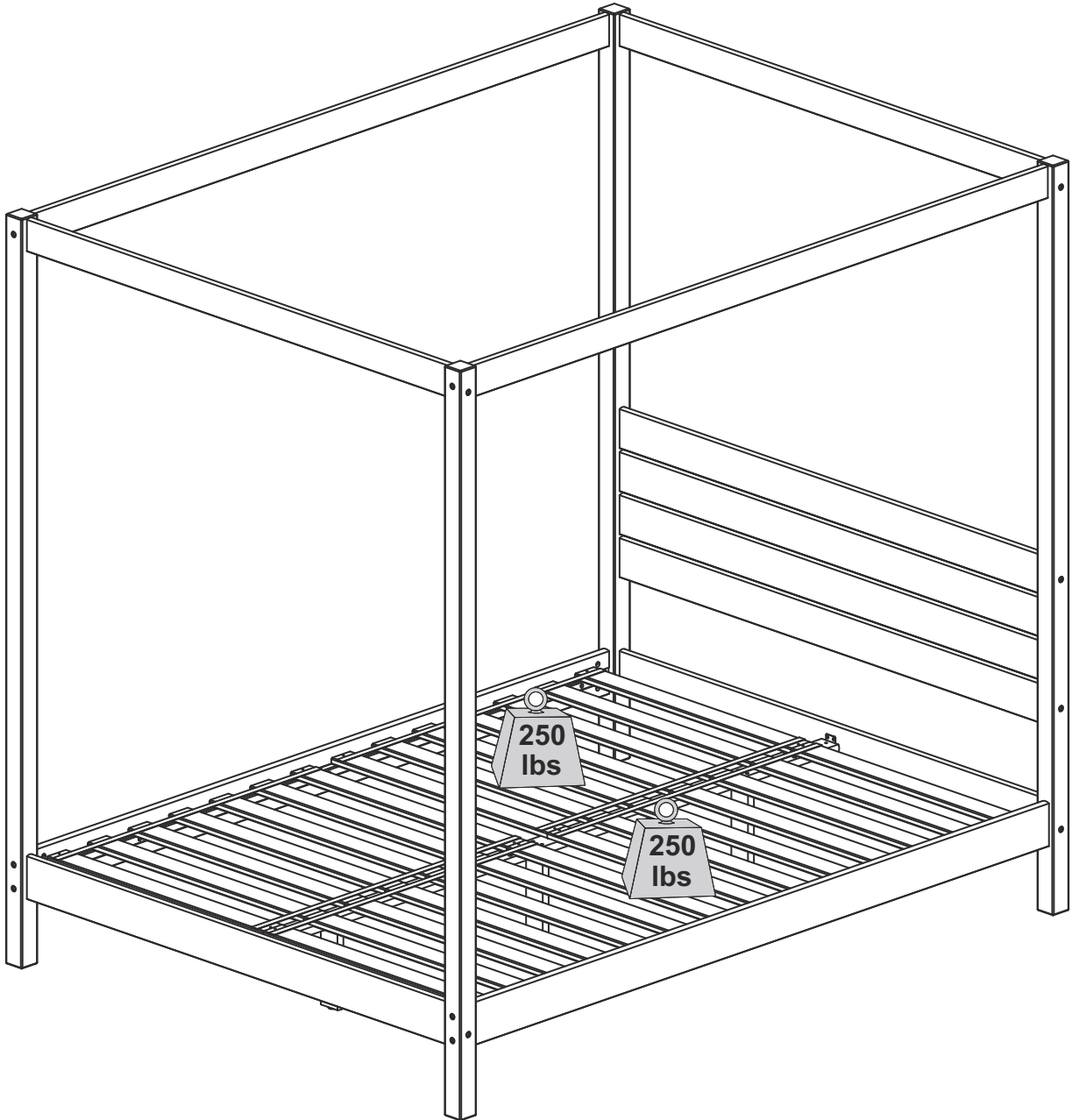

# Item #: ILSLB6B

## Assembly Instructions

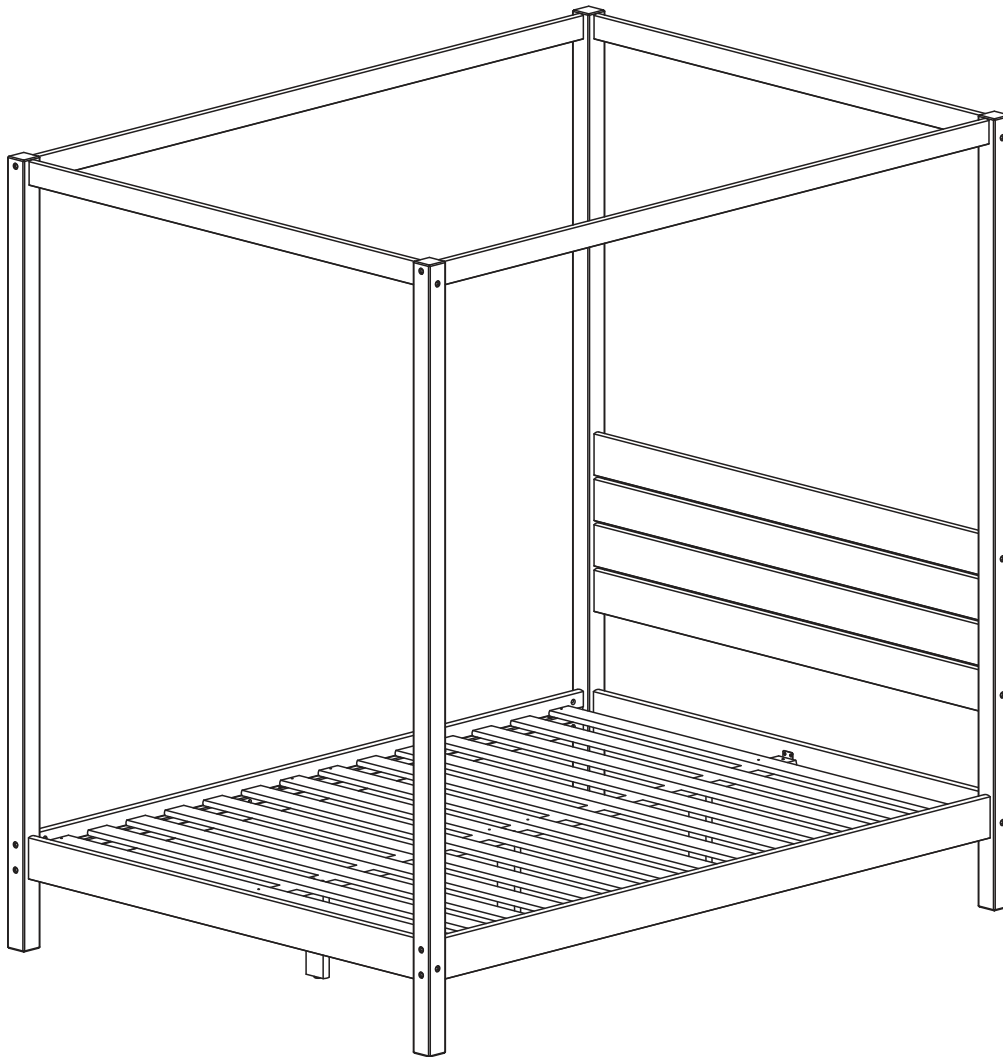

Please visit our website for the most current instructions, assembly tips, to report damage or request parts. [www.walkeredison.com](http://www.walkeredison.com)

Revised 10/2023 - V1



# General assembly guidelines

- I. Ensure that all parts and hardware are available before beginning assembly.
- II. Follow each step carefully to ensure the proper assembly of this product.
- III. Two people are recommended for ease in the assembly of this product.
- IV. The three main types of hardware used to assemble this product are wood dowels, screws and bolts.
- V. A hammer, Phillips head and Slotted head screwdrivers are required for the assembly of this product.

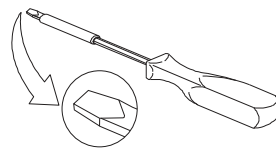
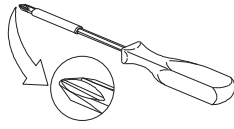
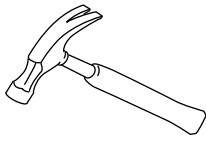

- VI. Power tools should not be used to assemble this product.

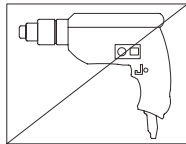



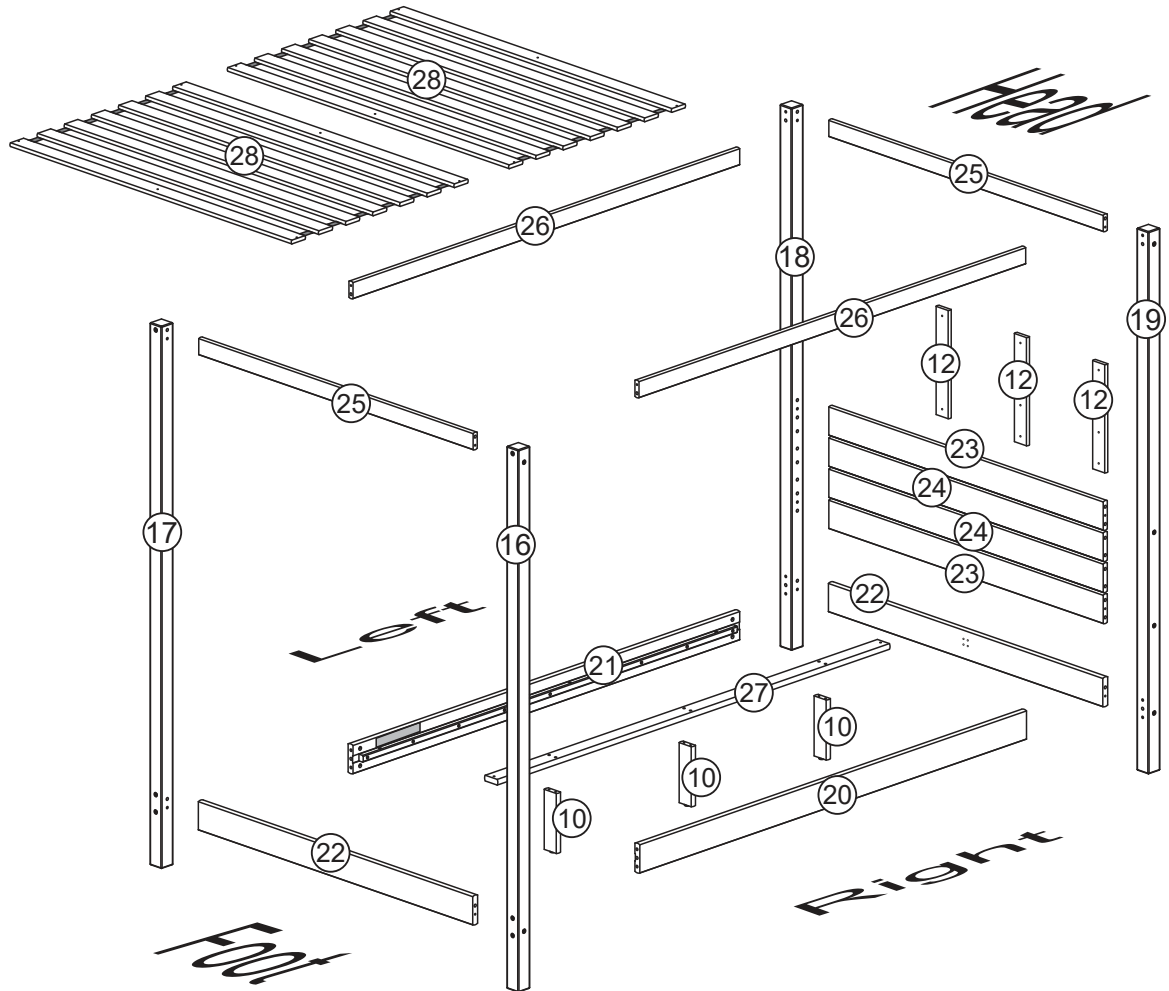



# Parts List

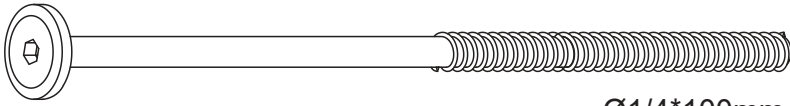
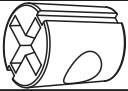
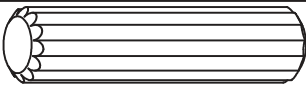
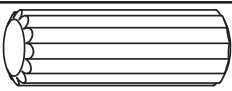
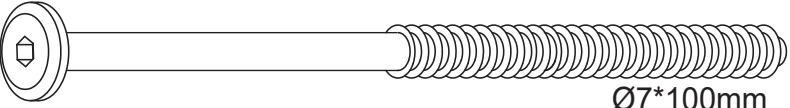
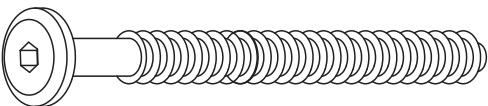

Part#	Description	Qty
10	Central Foot	3
12	Union Support	3
16	Footboard Right Post	1
17	Footboard Left Post	1
18	Headboard Left Post	1
19	Headboard Right Post	1
20	Right Side Rail	1
21	Left side rail	1
22	Head/Foot Rail	2

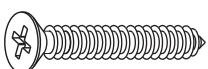
Part#	Description	Qty
23	Upper Rail / Lower Slat(HEADBOARD)	2
24	Middle Slat (HEADBOARD)	2
25	Upper Short Slat	2
26	Upper Long Slat	2
27	Central Support	1
28	Slat Set	2

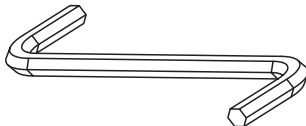
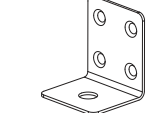
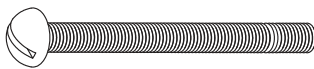
# Hardware List

<b>A</b>	 Ø1/4*100mm	Bolt (Head 13)	08 pcs	
<b>B</b>		1/4mm	Barrel nut	08 pcs
<b>C</b>		Ø10*40mm	Wooden dowel	32 pcs
<b>D</b>		Ø10*30mm	Wooden dowel	08 pcs
<b>E</b>	 Ø7*100mm	Bolt (Head 13)	16 pcs	
<b>F</b>	 Ø7*60mm	Bolt (Head 13)	06 pcs	
<b>G</b>		Ø4*35mm	Screw	12 pcs
<b>H</b>		Ø4*25mm	Screw	12 pcs
<b>I</b>		Ø3,5*16mm	Screw	08 pcs
<b>J</b>			Hex Key	01 pcs
<b>K</b>			Corner Brace	02 pcs
<b>L</b>		Ø3/16*1 1/2	Screw	02 pcs
<b>M</b>		Ø3/16	Nut	02 pcs
<b>N</b>		Ø3/16	Washer	02 pcs

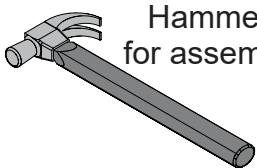

Hammer recommended for assembly (not included)

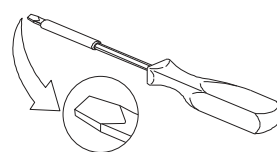
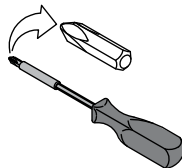

Phillips head and slotted head screwdrivers are required for assembly (not included)

The hardware quantities listed above are required for proper assembly. Some extra hardware may also have been included.

# Step 1

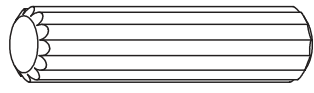
C		32
		Ø10*40mm

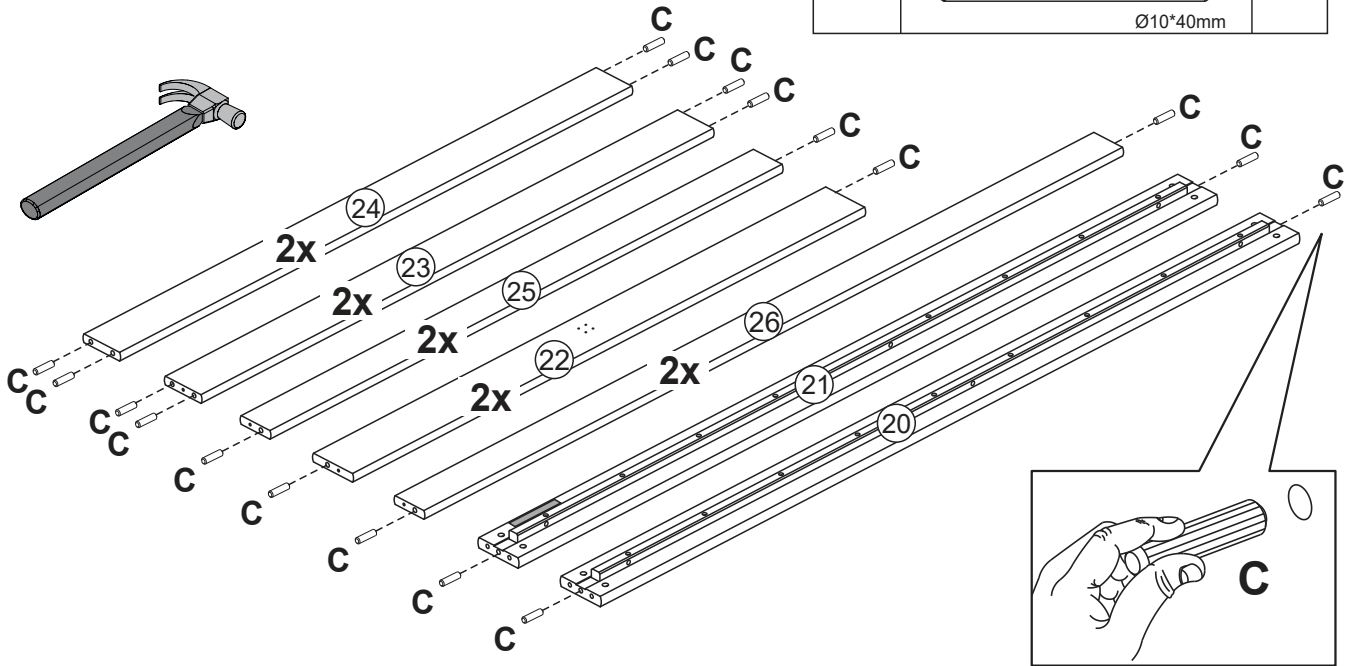

Insert wood dowel (C) into parts (20,21,22,23,24,25 and (26).

# Step 2

E		4
		Ø7*100mm

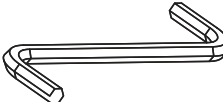
J		1
		Hex Key

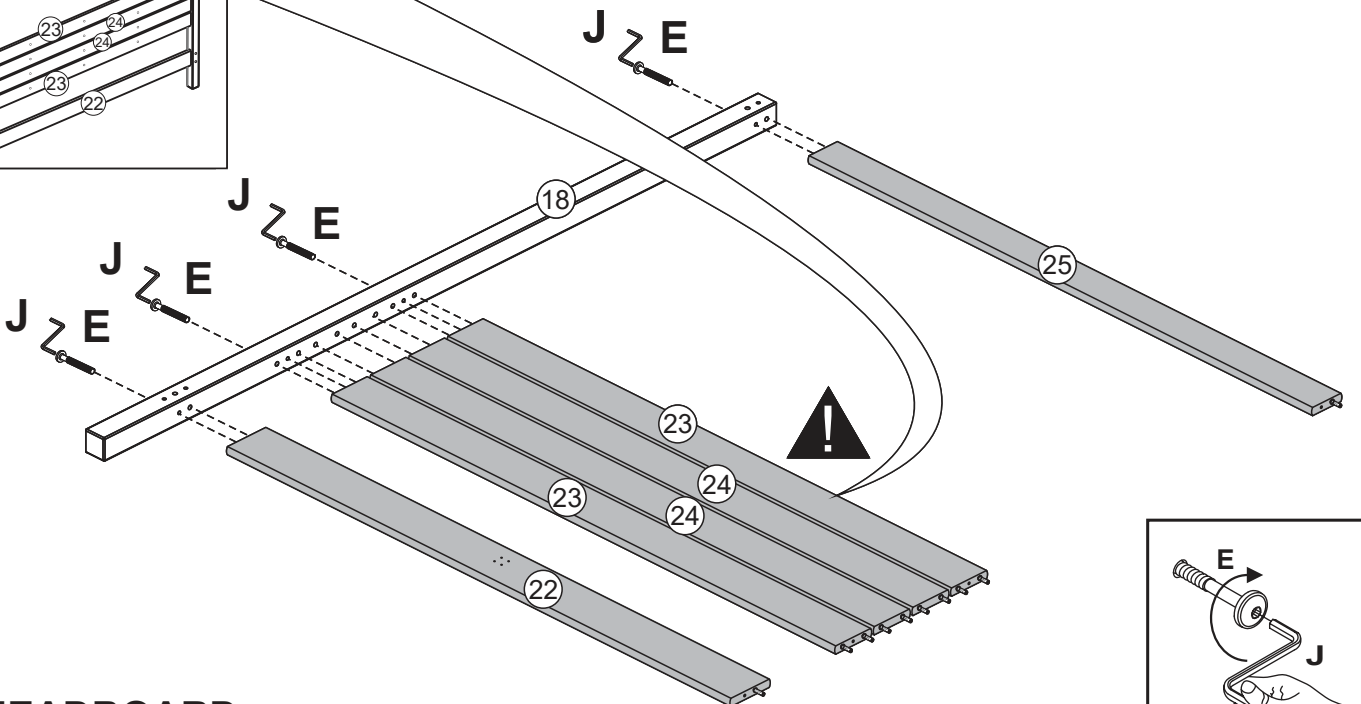
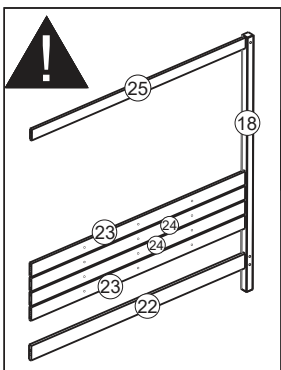

## HEADBOARD

Secure part 18 to parts 23, 22 and 25 with screw (E) using Hex Key (J).  
Align dowels part 24 to holes in part 18.

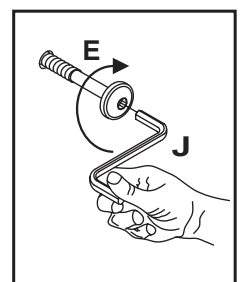

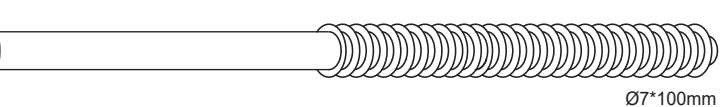
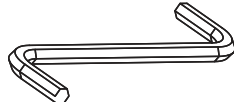

# Step 3

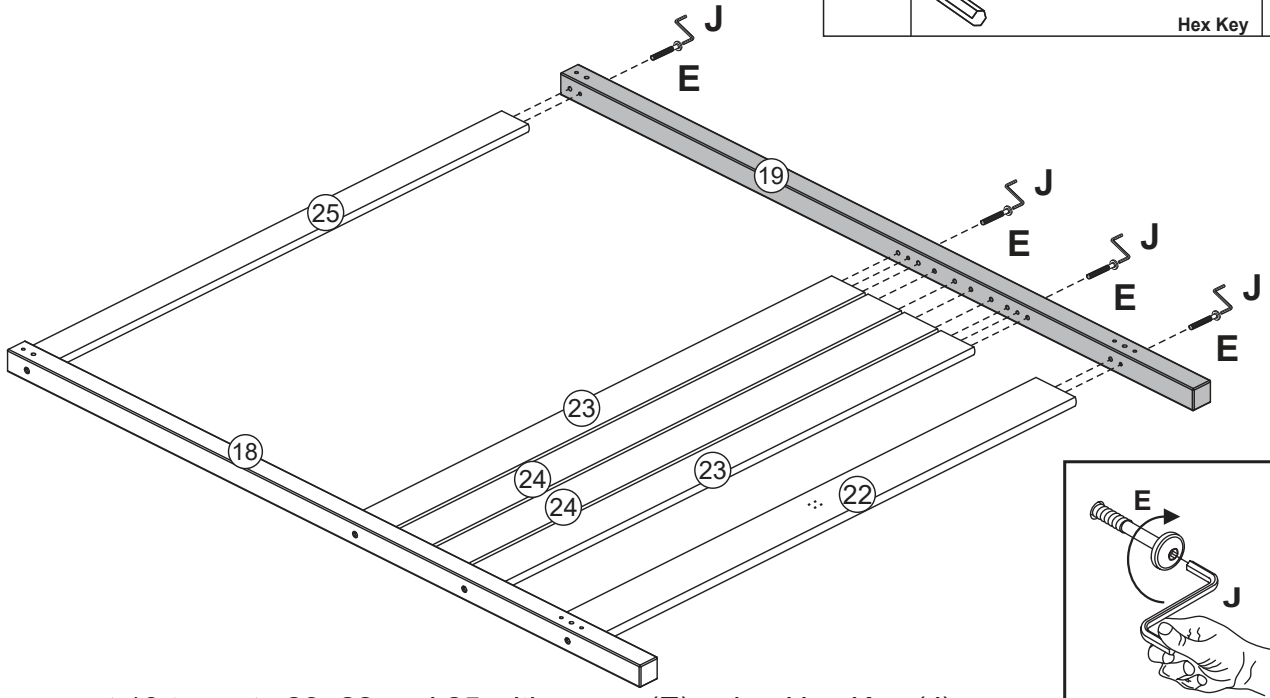
E		 Ø7*100mm	4
J		Hex Key	1

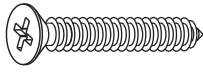

Secure part 19 to parts 23, 22 and 25 with screw (E) using Hex Key (J).  
Align dowels part 24 to holes in part 18.

# Step 4

H		 Ø4*25mm	12
---	---	--	----

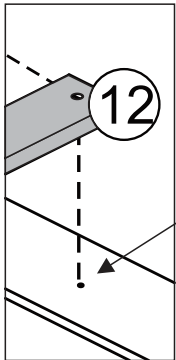

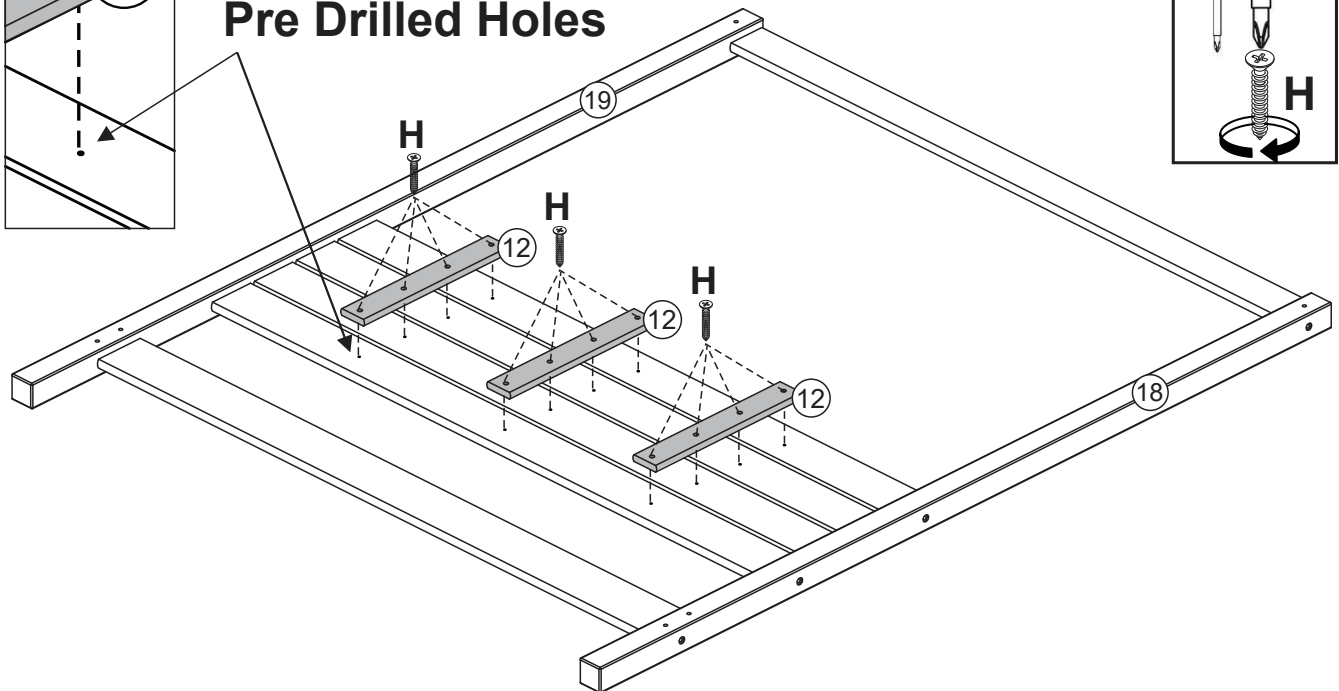

## Pre Drilled Holes



## HEADBOARD

Secure part 12 to headboard with screw (H) using phillips head screwdriver.

## Step 5

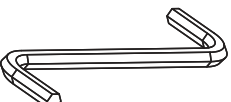

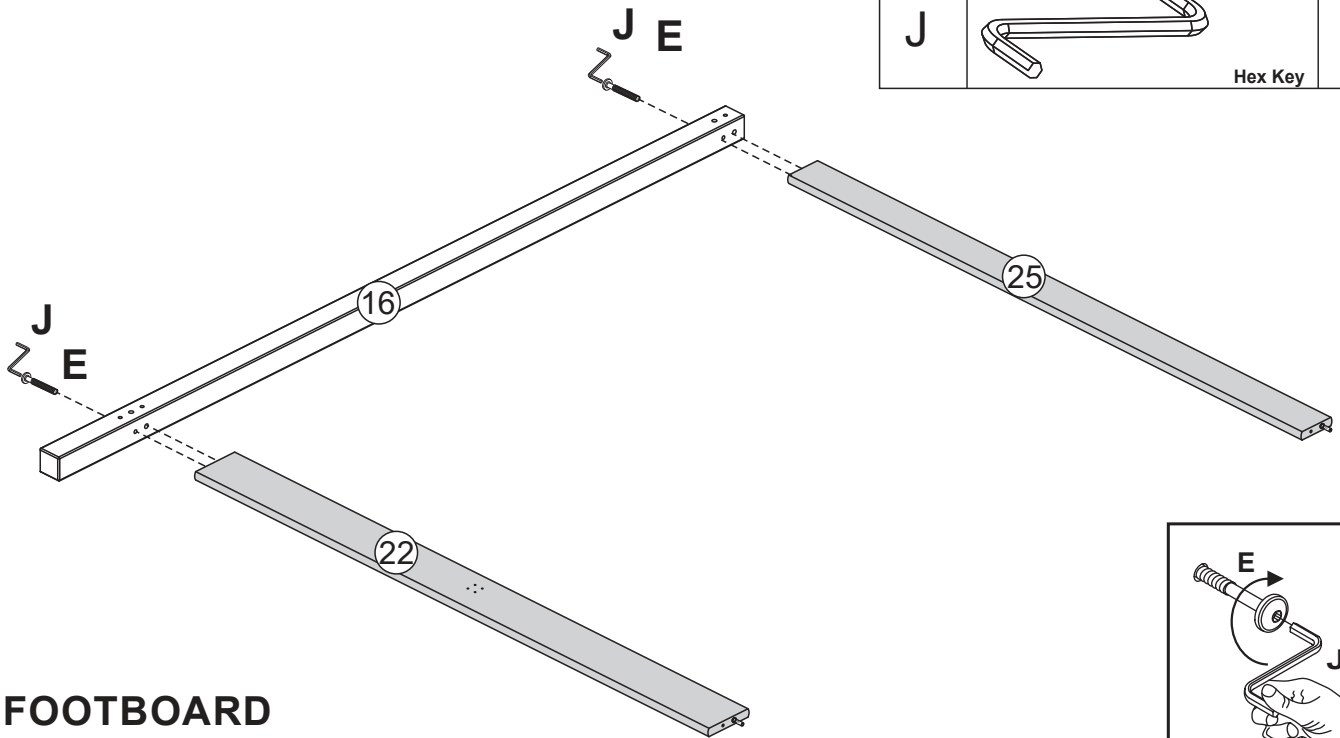
E			2
$\text{Ø}7 \times 100\text{mm}$			
J			1
Hex Key			



### FOOTBOARD

Secure part 16 to parts 22 and 25 with screw (E) using Hex Key (J).

## Step 6

E			2
$\text{Ø}7 \times 100\text{mm}$			
J			1
Hex Key			

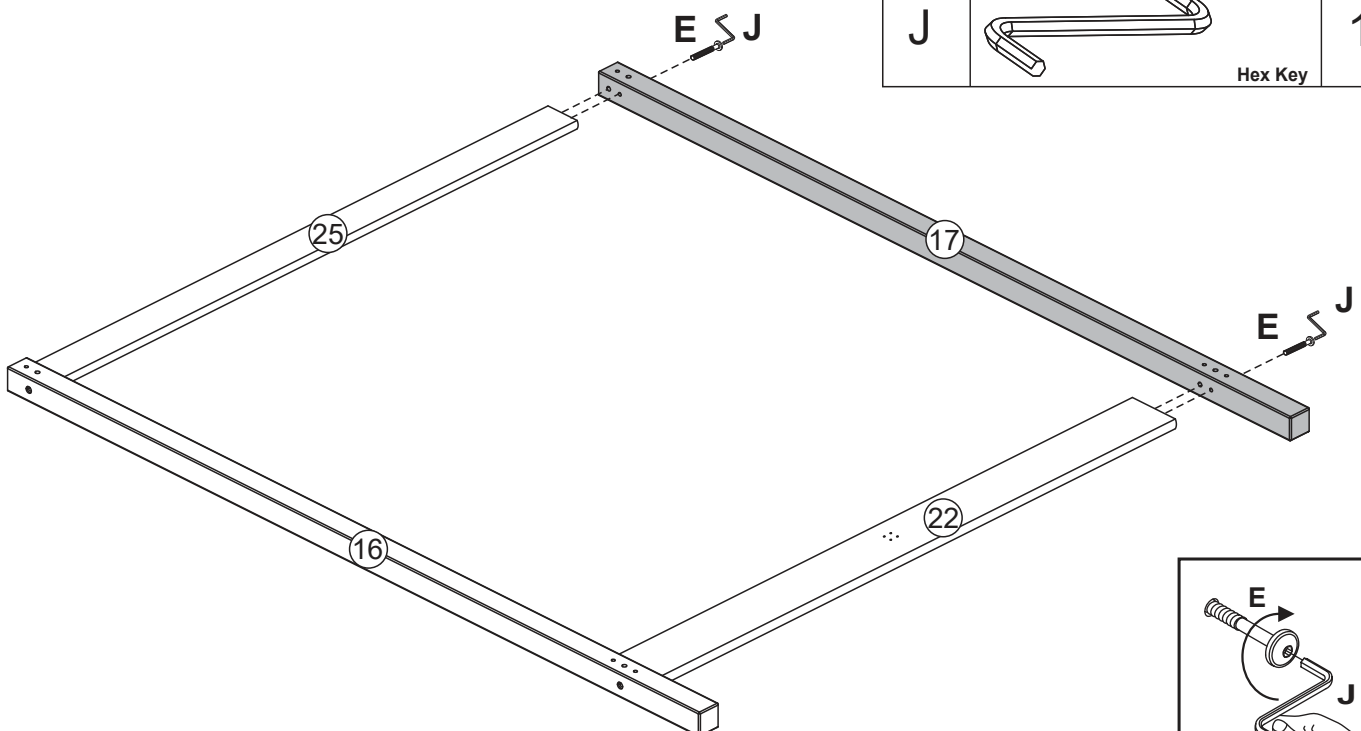

### FOOTBOARD

Secure part 17 to parts 22 and 25 with screw (E) using Hex Key (J).

# Step 7

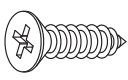
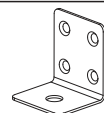
I		4	K		1
	Ø3,5*16mm			CORNER	

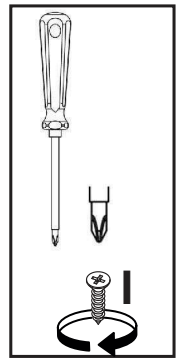
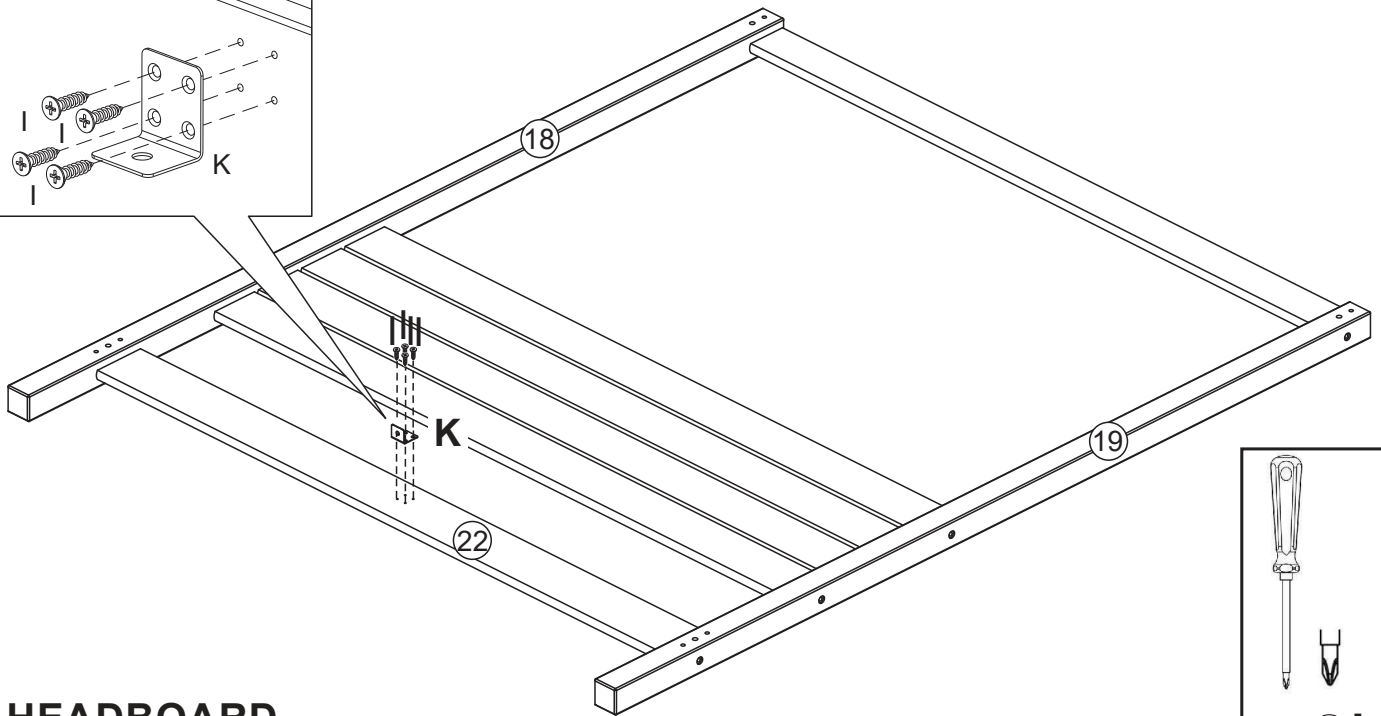
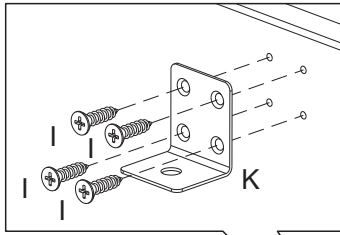

## HEADBOARD

Secure hardware (K) to headboard with screw (I) using phillips head screwdriver.

# Step 8

I		4	K		1
	Ø3,5*16mm			CORNER	

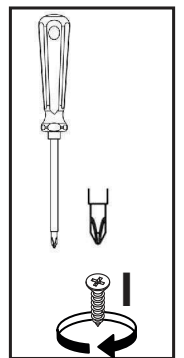
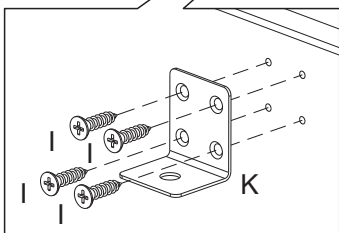
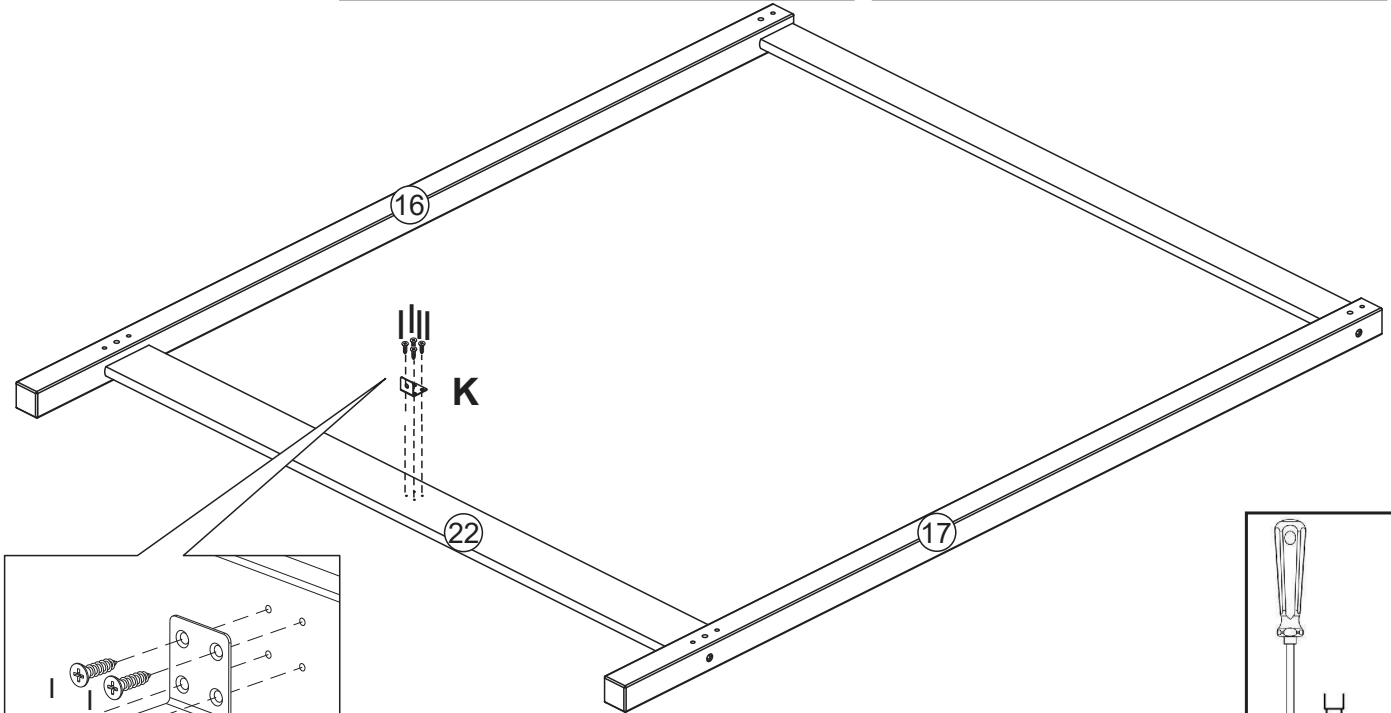

## FOOTBOARD

Secure hardware (K) to footboard with screw (I) using phillips head screwdriver.

# Step 9

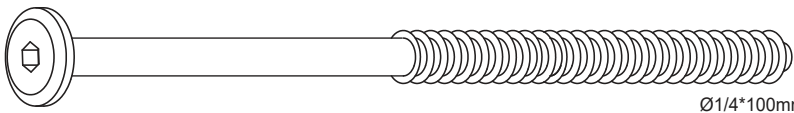
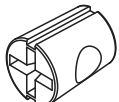
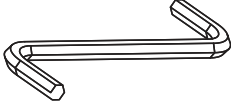
A		4
B		4
J		1

Ø1/4\*100mm  
1/4mm  
Hex Key

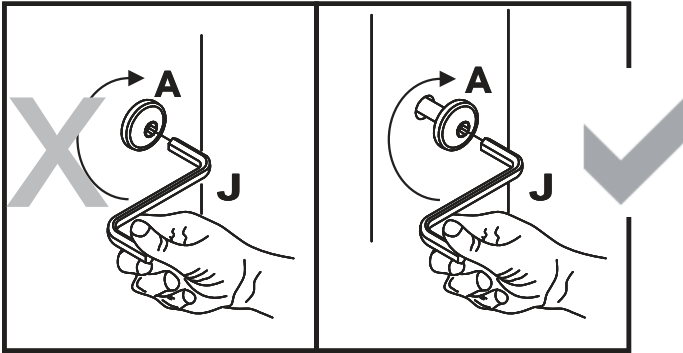

In this step, please do not tighten the screw all the way.

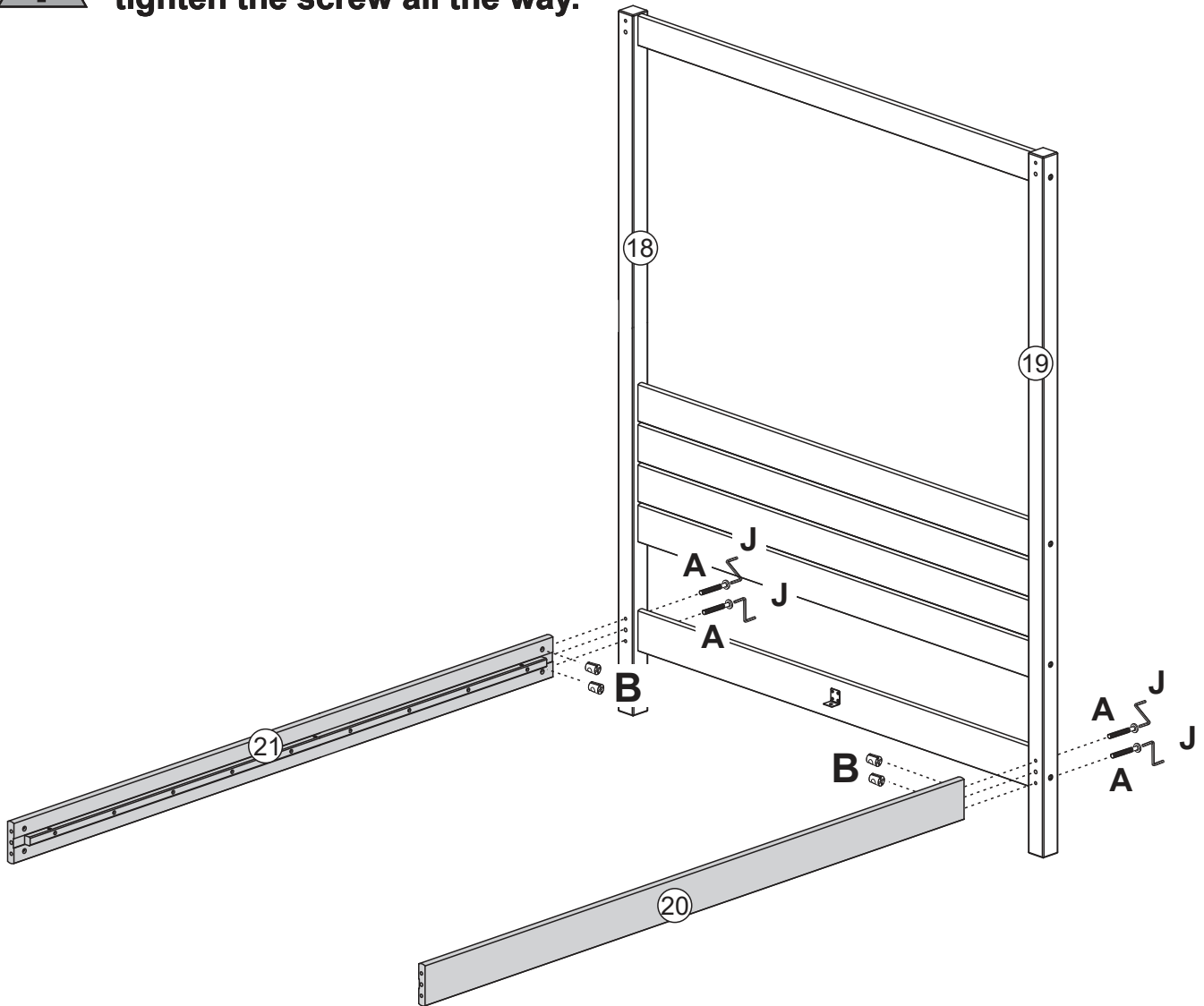

## HEADBOARD

Secure parts 21 and 20 to headboard Post 18 and 19 with crew (A) and barrel nut (B) using Hex Key (J).

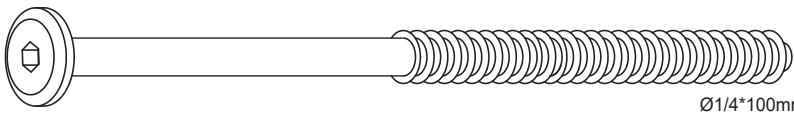
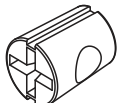
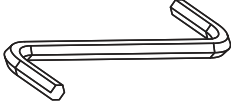

# Step 10

A		4
B		4
J		1

Ø1/4\*100mm  
1/4mm  
Hex Key

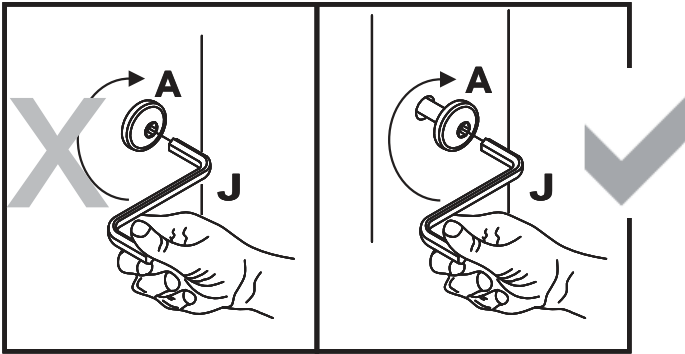

In this step, please do not tighten the screw all the way.

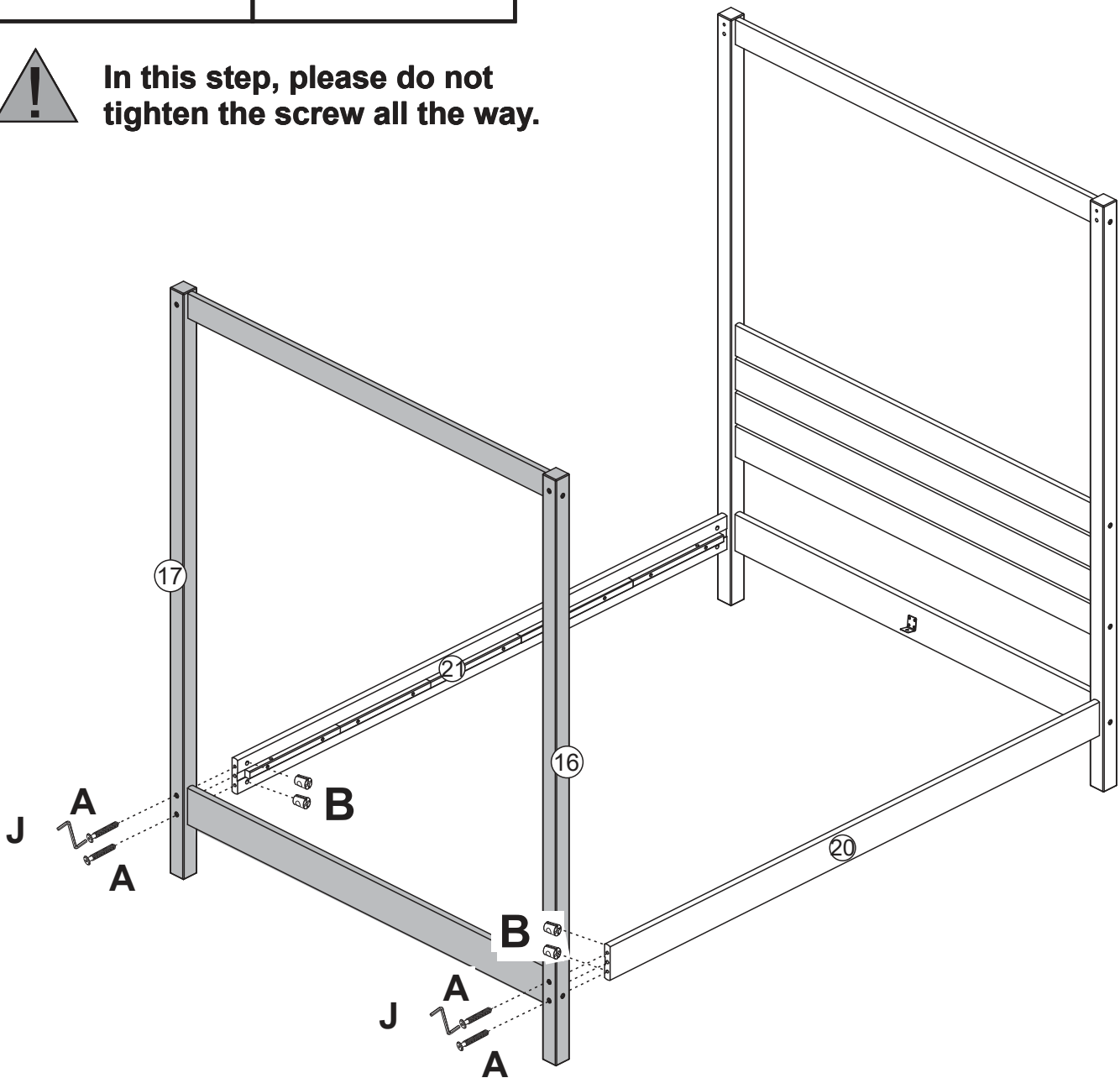

## FOOTBOARD

Secure part 21 and 20 to Footboard Post 16 and 17 with screw (A) and Barrel nut (B) using hex key (J).

# Step 11

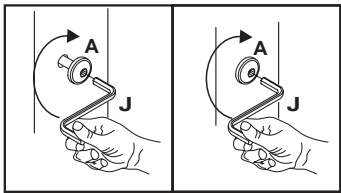
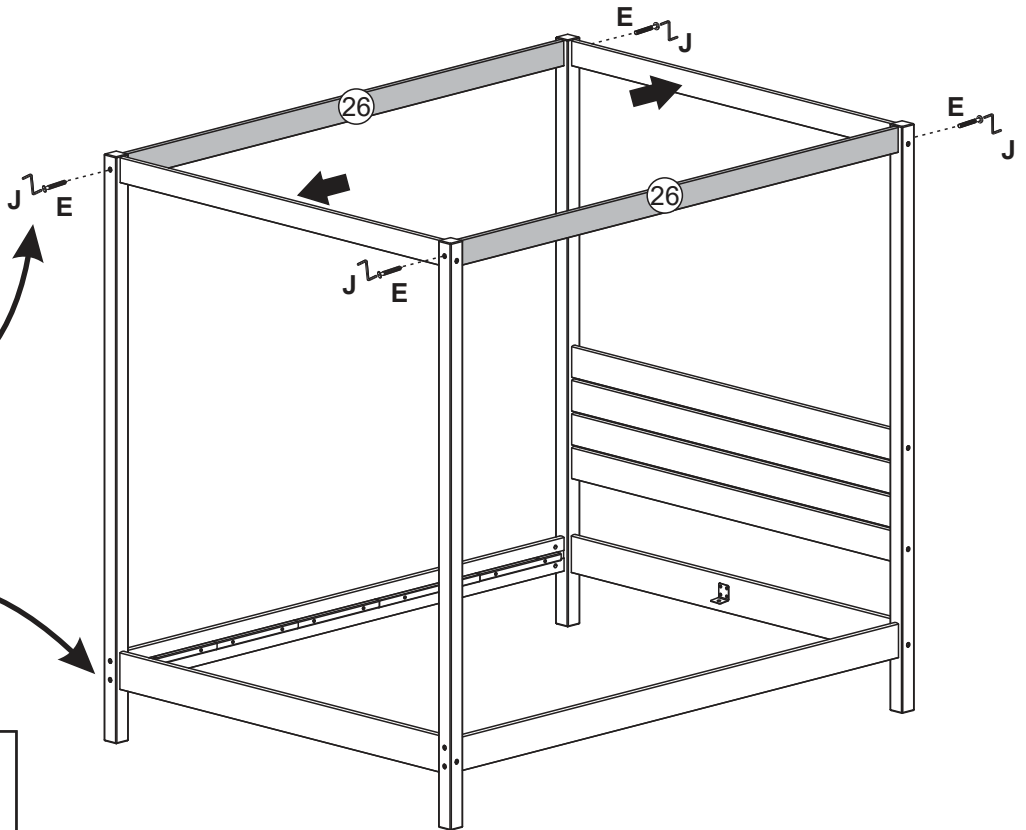
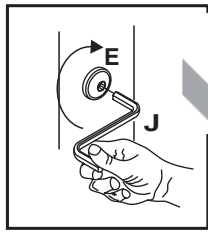

E	 <small>Ø7*100mm</small>	4
J	 <small>Hex Key</small>	1

**!** Finish tightening the screws from steps 9 and 10.

Secure part 26 with screw (E) using Hex Key (J).

# Step 12

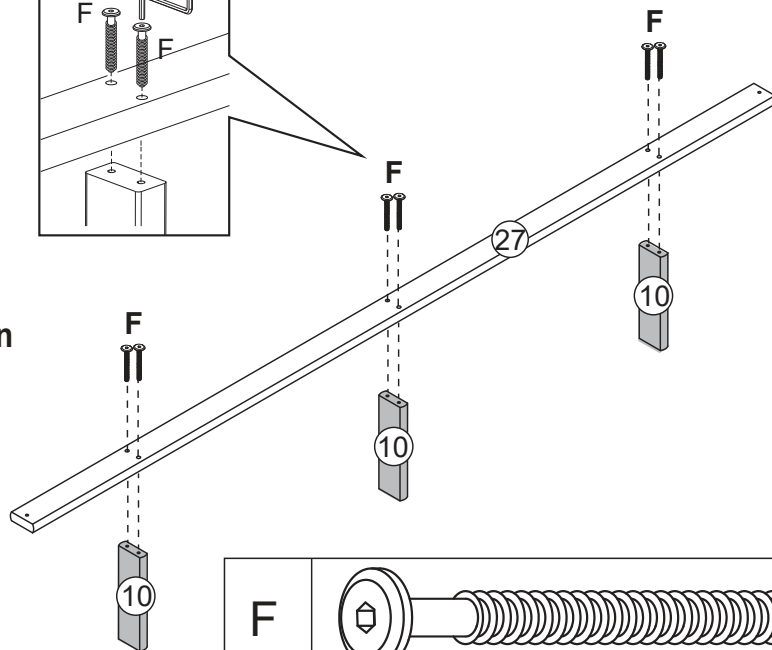
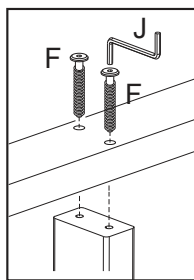
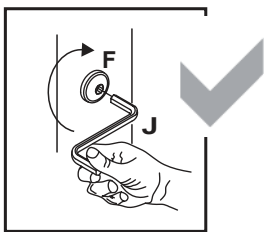



**!** In this step please tighten all screws completely.

F	 <small>Ø7*60mm</small>	6
J	 <small>Hex Key</small>	1

Secure part 27 to parts 10 with screw (F) using Hex Key (J).

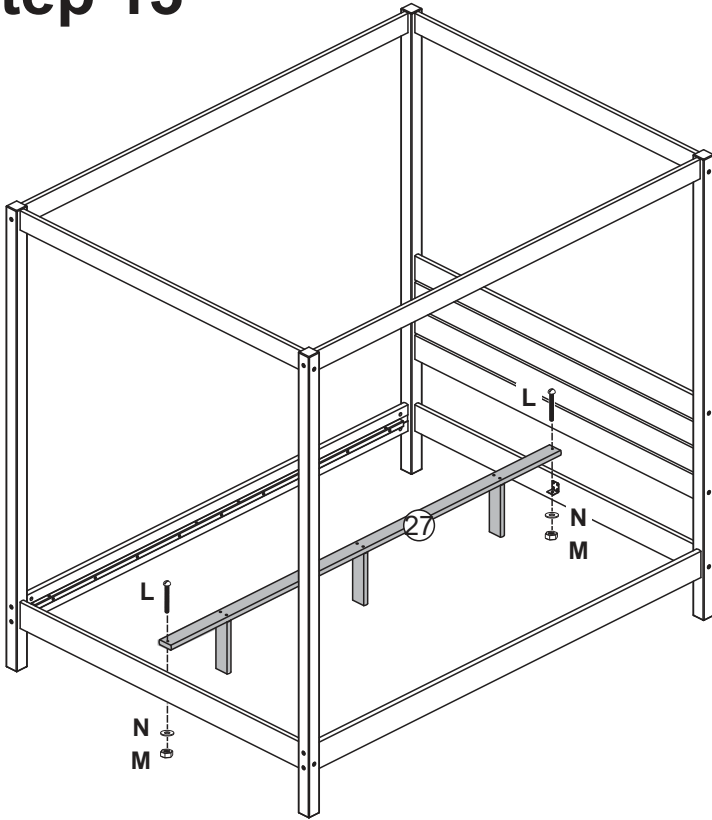
# Step 13

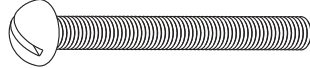

L	 Ø3/16*1.1/2	2
M	 3/16	2
N	 3/16	2

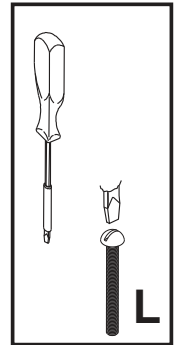
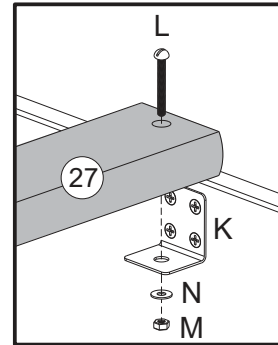

Secure part 27 to support (K) with screw (L) and washer (N) and nut (M) using slotted head screwdriver.

# Step 14

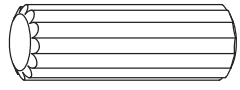
D	 Ø10*30mm	8
---	---	---

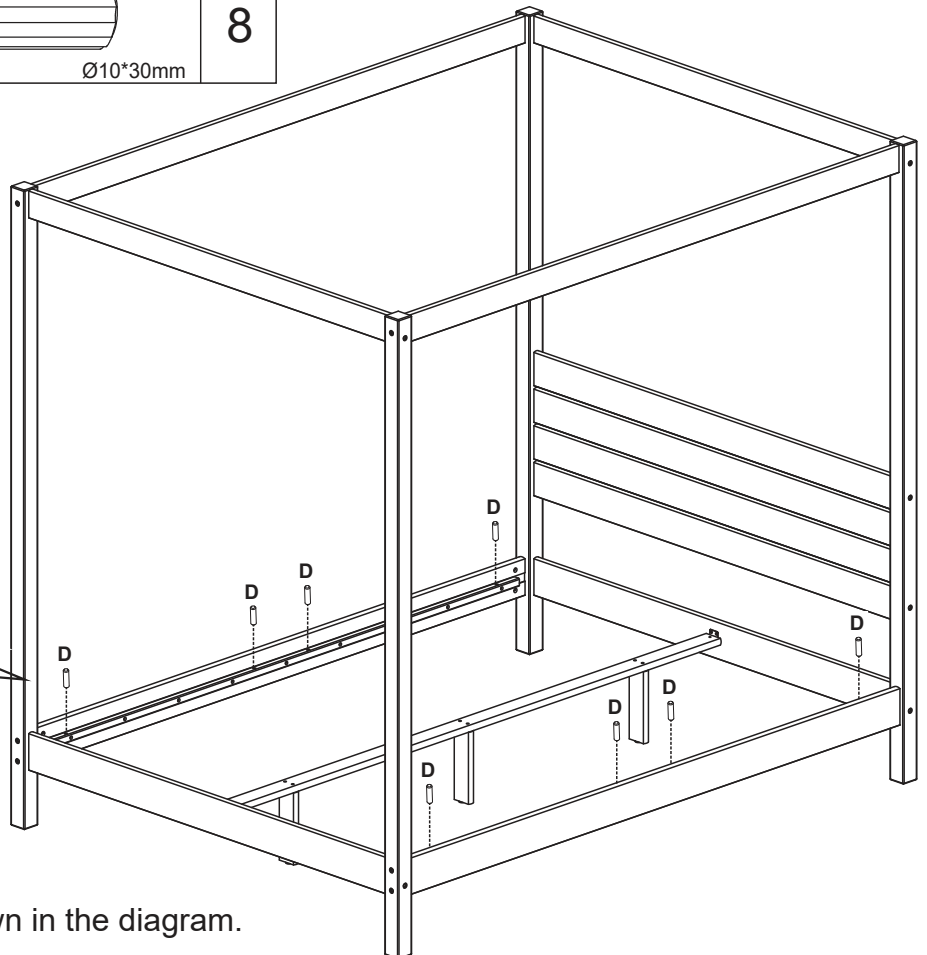
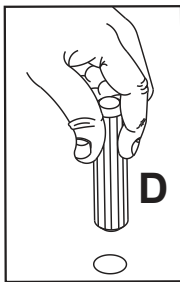
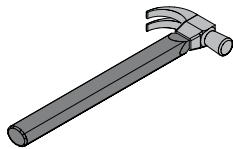

Insert wooden dowel (D) as shown in the diagram.

## Step 15

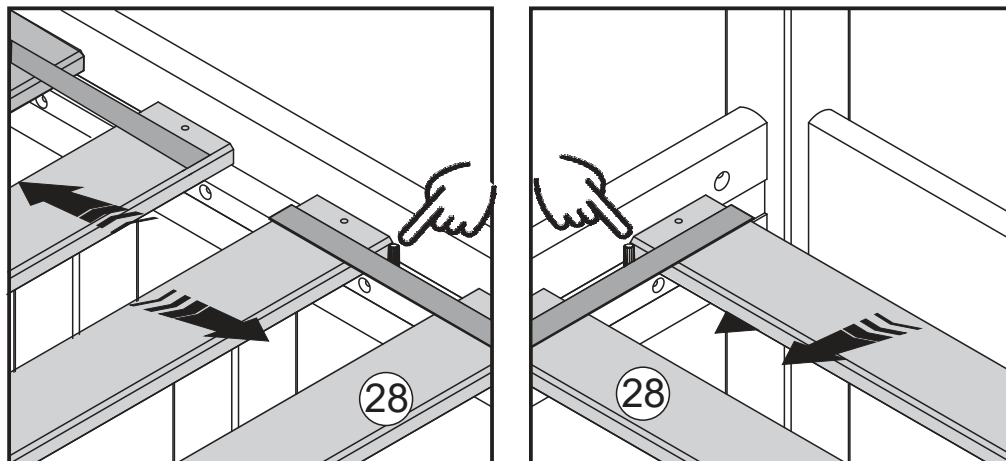

In this step, distribute sets of slats 28 using the applied dowels as guides.

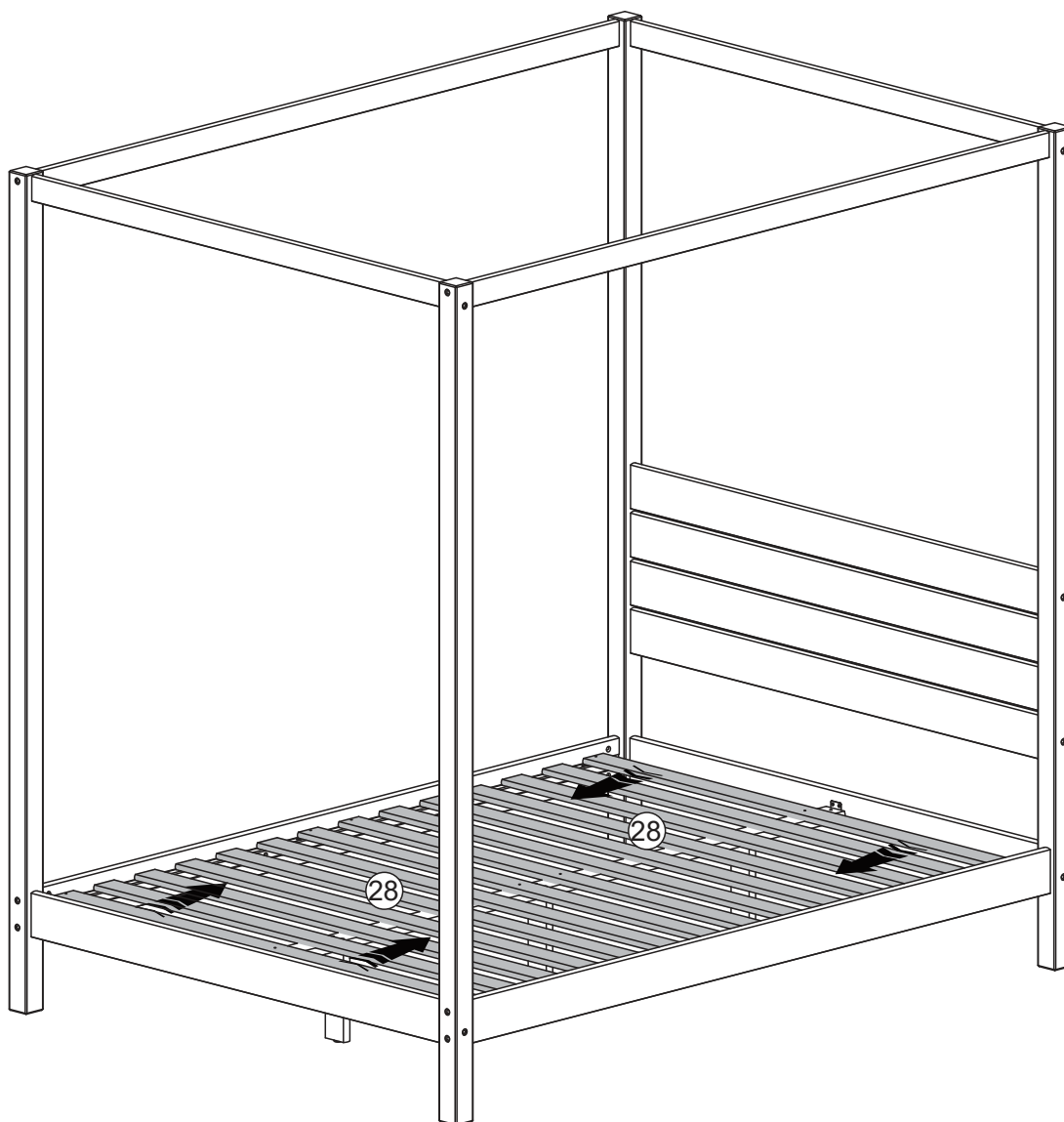

Insert the set of slats 28 as shown in the diagram.

# Step 16

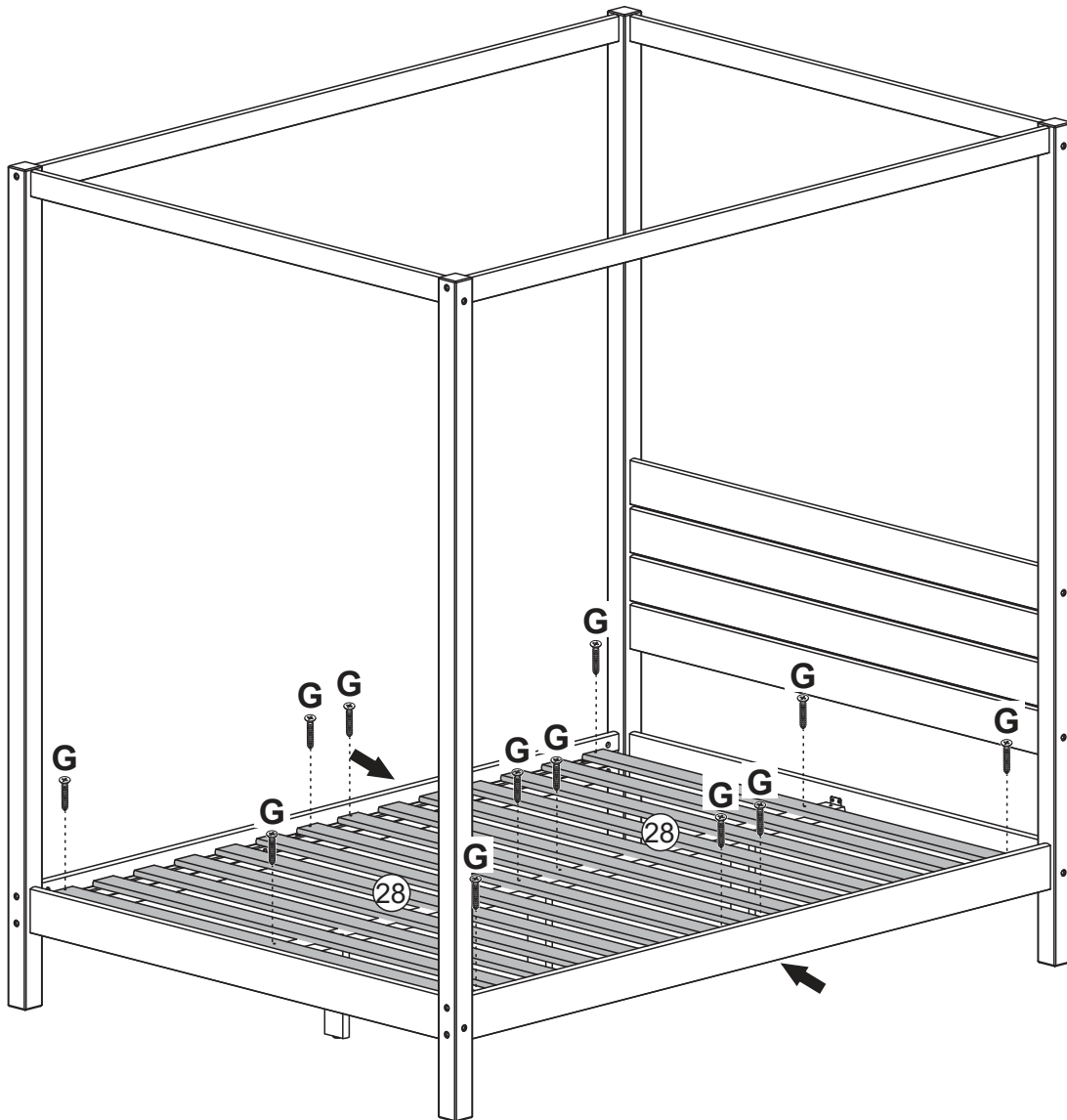
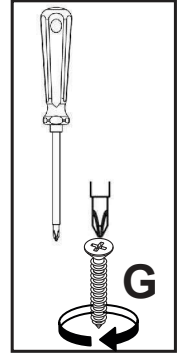
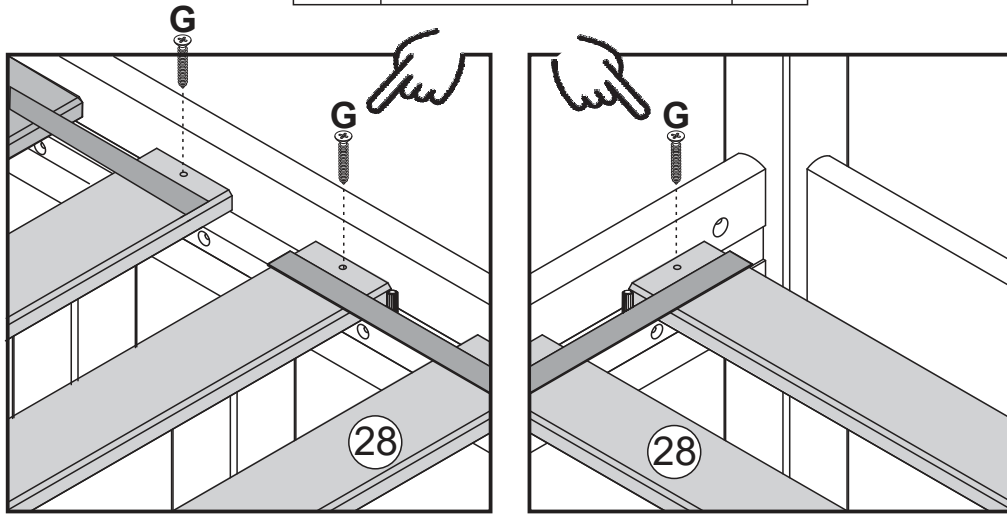
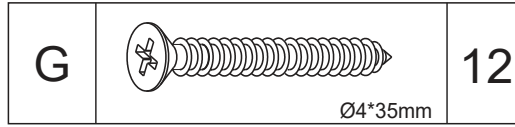

Secure the set of slats 18 with screw (G) using phillips head screwdriver.

# Step 17

